



VALLEY CHRISTIAN SCHOOLS™
HIGH SCHOOL

"Do it heartily as to the Lord." Col. 3:23

COURSE CATALOG

2018-2019

Table of Contents

Course Selection Policies	6
2018-2019 Academic Dates.....	8
Graduation Requirements	10
Math Map	11
Science Map	12
Social Science Map.....	13
AMSE Major/Minor Requirements	14
Conservatory Major/Minor Requirements	15
Course Remediation Policies	15
Transcript Policies.....	17
VCHS Homework Expectations	18
Time Commitment Worksheet.....	19
Course Offerings	20
VCHS Dual Credit Courses	21
VCHS Advanced Placement and Honors Courses.....	28
VCHS Approved A-G Courses for University of California & California State University.....	30
Bible	32
Foundations of Christianity	34
New Testament Studies	35
Biblical Literature/Spiritual Disciplines.....	36
Introduction to Life Calling/Applied Ethics	37
Philosophy of Religion.....	38
World Religions	38
Life Calling In The Workplace	39
The Truth Project/Spiritual Disciplines - Online	40
Biblical Leadership	41
Missions	42
ASB Biblical Government.....	43
Community Outreach	44
Arts Outreach – Conservatory of the Arts.....	45
Christian Athletic Leadership – Human Performance.....	46
Advanced Biblical Leadership	47
Advanced Community Outreach	48
Dance Arts.....	49
Dance Technique I	51
Dance Technique II	52
Dance Technique III	53
Color Guard I.....	54
Color Guard II.....	55
Color Guard III.....	56
Dance Technique III Honors.....	57
Tap I.....	58
Tap II.....	59
Tap III.....	60
Hip Hop I	61
Hip Hop II	62
Hip Hop III	63
English.....	64
English 9	66
English 9 Honors*.....	67
English 10	68
English 10 Honors*.....	69
American Literature	70
African American Literature	71
Sports in Literature and Writing.....	72
Philosophy in Literature.....	73
AP English Language and Composition	74
Early British Literature	75
Late British Literature	75

AP English Literature and Composition.....	76
Math	77
Algebra I (Meets Daily).....	79
Algebra I.....	80
Geometry (Meets Daily)	81
Geometry	82
Geometry Honors*.....	83
Algebra II (Meets Daily).....	84
Algebra II.....	85
Algebra II Honors*	86
Finite Math	87
Consumer Math - Online	88
Trigonometry/Pre-Calculus.....	89
Trigonometry/Pre-Calculus AB.....	90
Trigonometry/Pre-Calculus BC Honors	91
Statistics.....	92
AP Statistics.....	93
Advanced Data Analysis*	94
Calculus	95
AP Calculus AB.....	96
AP Calculus BC.....	97
Multivariable Calculus*	98
Music Arts.....	99
Symphonic Band	101
Wind Ensemble	102
Jazz Lab.....	103
Jazz Ensemble Honors	104
String Ensemble.....	105
Chamber Ensemble.....	106
Percussion Ensemble.....	107
Piano I	108
Piano II	109
Piano III.....	109
Introduction to Guitar and Electric Bass	110
Guitar II	111
Guitar III	112
Conservatory Chorus	113
Worship Choir	114
Conservatory Ensemble	114
Vocal Jazz Ensemble	115
AP Music Theory.....	116
Music Technology	117
New Media Studies	118
The Art of Filmmaking	120
Applied Filmmaking	121
Advanced Applied Filmmaking	122
3D Film Animation	123
Advanced 3D Animation.....	123
TV Broadcast Journalism	124
Advanced TV Broadcast.....	125
Journalism I.....	126
Journalism II.....	127
Physical Education.....	128
Lifetime Fitness	130
Foundations of Baseball.....	131
Foundations of Water Polo.....	131
Foundations of Hockey.....	132
Foundations of Soccer	132
Football Performance	133
Outdoor Athletic Performance	133
Indoor Athletic Performance.....	134
Science.....	135

Biology	137
Marine Biology	138
Biology Honors*	139
Anatomy and Physiology.....	140
Anatomy and Physiology Honors	141
AP Biology.....	142
Astronomy	143
Chemistry	144
Chemistry Honors*	145
AP Chemistry	146
Physics.....	147
AP Physics 1	148
AP Physics C: Mechanics/E&M.....	149
Integrated Science	150
AP Environmental Science.....	151
Social Science.....	152
Origins of Global Issues	154
History and Music.....	155
Modern World History.....	156
Modern World History Honors*	157
AP Human Geography	158
U.S. History	159
AP United States History.....	160
United States Government	161
Economics.....	161
AP United States Government & Politics.....	162
AP Microeconomics.....	163
Business & Technology.....	164
Introduction to Computer Programing	166
AP Computer Science A.....	167
iPad Technical Support Internship	168
PLTW: Introduction to Engineering Design	169
PLTW: Principles of Engineering.....	170
PLTW: Aerospace Engineering (AE).....	171
Introduction to Entrepreneurship	172
Advanced Business Honors	173
Speech	174
Debate.....	174
Theatre Arts	175
Theatre I.....	177
Theatre II.....	178
Theatre II Honors	179
Improvisational Theatre.....	180
Musical Theatre.....	180
Technical Theatre I.....	181
Technical Theatre II.....	182
Technical Theatre II Honors	183
Advanced Design and Stage Production Internship	184
Visual Arts	185
Ceramics I.....	187
Ceramics II	188
Art I.....	189
Art II.....	189
Art III.....	190
AP Studio Art: Drawing.....	190
AP Studio Art: 2D Design	191
Photographic Design I.....	192
Photographic Design II	193
Photographic Design Studio.....	194
AP Art History.....	195
Graphic Design	196
Yearbook.....	196

World Language.....	197
American Sign Language I.....	199
American Sign Language II.....	200
American Sign Language III.....	200
American Sign Language IV.....	201
Chinese (Mandarin) I.....	202
Chinese (Mandarin) II.....	203
Chinese (Mandarin) III.....	204
Chinese (Mandarin) IV Honors.....	205
AP Chinese (Mandarin) Language and Culture.....	206
French I.....	207
French II.....	208
French III.....	208
French IV Honors.....	209
Latin I.....	210
Latin II.....	211
Latin III.....	211
Latin IV Honors.....	212
AP Latin.....	213
Spanish I.....	214
Spanish II.....	215
Spanish III.....	215
Spanish III Honors.....	216
Spanish IV.....	216
AP Spanish Language & Culture.....	217
Electives.....	218
Scientific Research.....	220
ASB Student Government.....	221
Study Hall.....	222
Teacher's Aide.....	222
Specialized Aide.....	223
Open Period or Unscheduled.....	223
Language Skills for International Students.....	224

COURSE SELECTION POLICIES

COURSE SELECTION AND ENROLLMENT

Students must be formally enrolled at Valley Christian High School for the upcoming school year in order to select courses. The course selection process for currently enrolled students occurs between January-March.

STUDENT COURSE ADVISING

Each year, counselors and teachers assist students in selecting the best courses for the following year. Advice is given in a variety of formats including individual counselor meetings, short classroom presentations, and teacher conferences.

Students may make an appointment with their counselor to further discuss course selection, but it is strongly advised to first ask and follow the recommendation of the current teacher. Teachers will provide the most individualized and subject-specific advice.

PREREQUISITES AND RECOMMENDATIONS

The course catalog includes prerequisites and/or recommendations for each course. Please read them carefully before selecting courses. All grade prerequisites are listed as a general letter grade (no pluses/minuses), but the student's specific grade percentage may be considered when the course list is reviewed by counselors and teachers. Recommendations are important factors that have proven consistent with student success in the classroom.

COURSE LIST REVIEW

Counselors and teachers review course lists, checking that each student has met the prerequisites, but it is ultimately the student's responsibility to be aware of the prerequisites and to be sure he/she is enrolled in appropriate courses.

If a student has not met the prerequisite, he/she may be removed from the course and placed in the appropriate level course.

If a teacher or counselor has a concern about a student's ability to succeed in a course, the counselor or teacher will notify the student of the concern and review possible options.

ENROLLMENT APPEALS

If a student does not meet the prerequisites and feels there should be an exception made due to a unique circumstance, the student should write a formal request to the counselor with his/her reasoning. The counselor can then present the appeal to the current teacher and/or future teacher for consideration.

If the student is denied admittance to a course due to concerns expressed by the current teacher and/or future teacher and still wants to enroll, the student should speak to the counselor. In some circumstances the student and parent may need to sign a contract, documenting that they both understand the student is enrolling in a course against counselor and teacher recommendation. Other times the original denial must stand due to the particular demands of the course.

COURSE CONFLICTS

Valley Christian High School works diligently to minimize course conflicts, but students with several specialized course requests may be asked to prioritize their course requests. If a student is unable to take a course due to a conflict, the counselor will notify him/her. If the counselor notifies a student of a conflict, the school has already made attempts to move the courses to make the schedule work but was unable to find a solution.

COURSE CHANGE REQUESTS

Once the course list is posted in Power School for parental review, the student's course list becomes finalized for the upcoming year. Unless a counselor contacts the student with a conflict or concern, the course list is considered fixed until the start of school. Counselors will not make changes based on preference or due to a new request over the summer. Student course lists are frozen until August.

NOTE ON COURSE NUMBERS

Note that Course numbers are subject to change, please refer to Power School for current course numbers

2018-2019 ACADEMIC DATES

AUGUST

First Day of School	August 15
In Service – No School	August 31

SEPTEMBER

Labor Day - No School	September 3
Last day to add a new academic course	September 7

OCTOBER

Last day to drop a course without a W/F	October 9
End of Quarter 1	October 12
Predicted PSAT Minimum Day	October 10
In Service – No School	October 19
Staff Retreat – No School	October 22
Last day for AP/honors to drop to CP equivalent	October 26

NOVEMBER

Thanksgiving Break	November 21-23
--------------------	----------------

DECEMBER

Final Exam Week (Special Schedule)	December 17-20
End Semester 1	December 20

JANUARY

School Resumes	January 8
Martin Luther King Jr.'s Birthday – No School	January 21
Last day to add a new academic course	January 25

FEBRUARY

Re-Enrollment	February 1-28
Winter Break – No School	February 18-22

MARCH

Last day to drop a course without a W/F	March 7
In Service – No School	March 8
End Quarter 3	March 15
Last day for AP/honors students to drop to CP equivalent	March 22

APRIL

Easter Break – No School	April 15-22
--------------------------	-------------

MAY

AP Exam Administration	May 6-17
Memorial Day – No School	May 27
Final Exam Week (Special Schedule)	May 28-31
End of Semester 2	May 31

JUNE

Graduation	June 1
------------	--------

GRADUATION REQUIREMENTS

Each student is expected to spend a full four years in high school. Attending summer school or carrying more than a normal load during the regular school year should be regarded as an enrichment of the student's education rather than an accelerated program.

Course standing will be based on the total number of credits successfully achieved.

To be eligible for school activities:

- Sophomores must have completed 50 credits.
- Juniors must have completed 100 credits.
- Seniors must have completed 155 credits.

A senior will not be awarded a diploma and may not participate in the graduation ceremony until he/she has completed all requirements and accumulated the total credits necessary. All financial obligations, including a graduation fee, must be met before the student can participate in commencement exercises.

Students are expected to enroll in a full seven period course load, with exceptions for seniors meeting graduation requirements who may be permitted to have an unscheduled first or last period. They must, however, leave campus or be in supervised areas during this unscheduled time.

CREDITS	YEAR	SUBJECT AREA
40	4	Bible [‡]
40	4	English
30	3	Math
10	1	Physical Education/Health
20	2	Science
30	3	Social Studies/History
10	1	Visual & Performing Arts
20	2	World Language
40	4	Electives
240	TOTAL MINIMUM CREDITS REQUIRED TO GRADUATE	

[‡]*Bible is required for each semester of attendance at VCHS. Required Bible credits are waived for any semester that the student does not attend VCHS. These credits are then added to the required elective credits.*

MATH MAP

Three years of math are required to graduate from VCHS. Students should reach Algebra II in order to be college eligible. VCHS highly recommends four years of math to compete in the college market.

Students will start at a variety of different levels based on previous completed math courses.

* Finite, Statistics, and Trig/Pre-Calc can be taken in any order. Trig/Pre-Calc must be taken before Calculus.

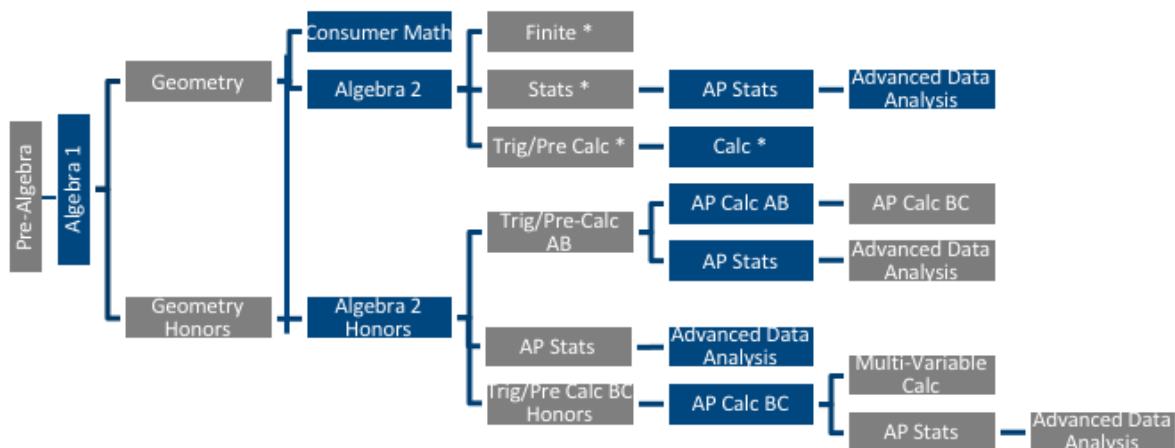

This map is intended as a general planning tool that shows the typical tracks students at VCHS follow. Students can deviate from the map and should consult with their counselors and teachers to find the best math courses to meet their academic goals.

SCIENCE MAP

Two years of science are required to graduate from VCHS. Students should reach the chemistry level, and, for those looking to be accepted to a UC, physics is preferred. VCHS highly recommends at least three years of science.

Students will start at a variety of different levels based on previously completed science courses.

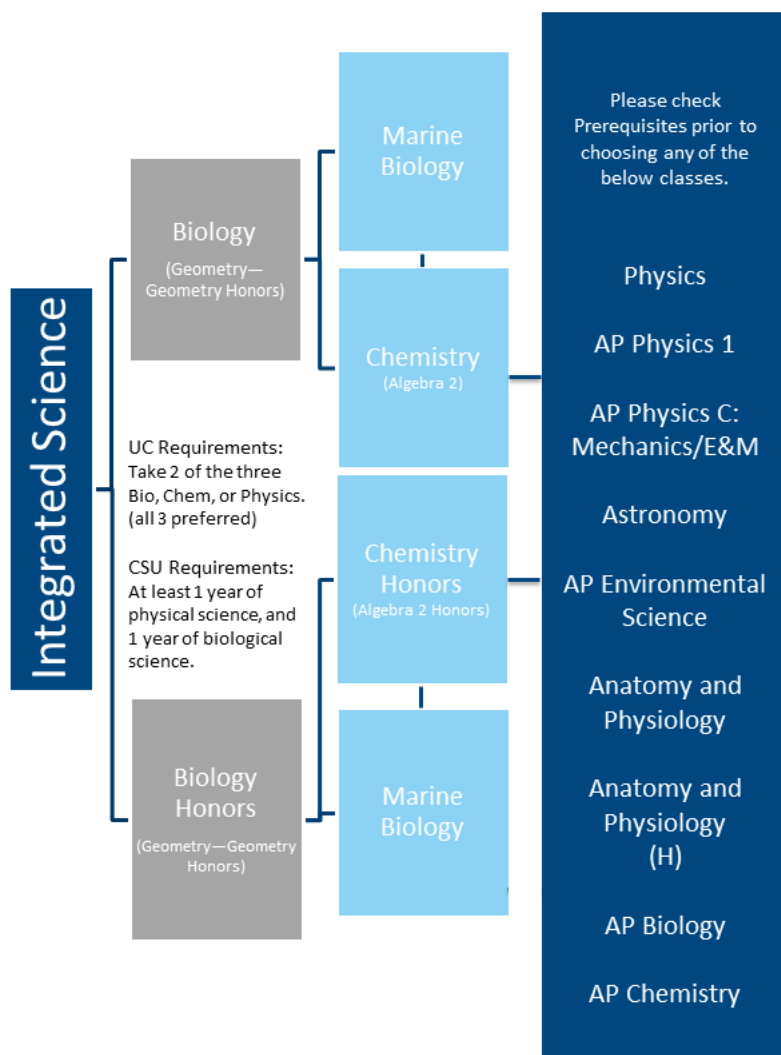

This map is intended as a general planning tool that shows the typical tracks students at VCHS follow. Students can deviate from the map and should consult with their counselors and teachers to find the best science courses to meet their academic goals.

SOCIAL SCIENCE MAP

Three years of social science are required to graduate from VCHS. Students must take a US history course their junior year and a civics course their senior year.

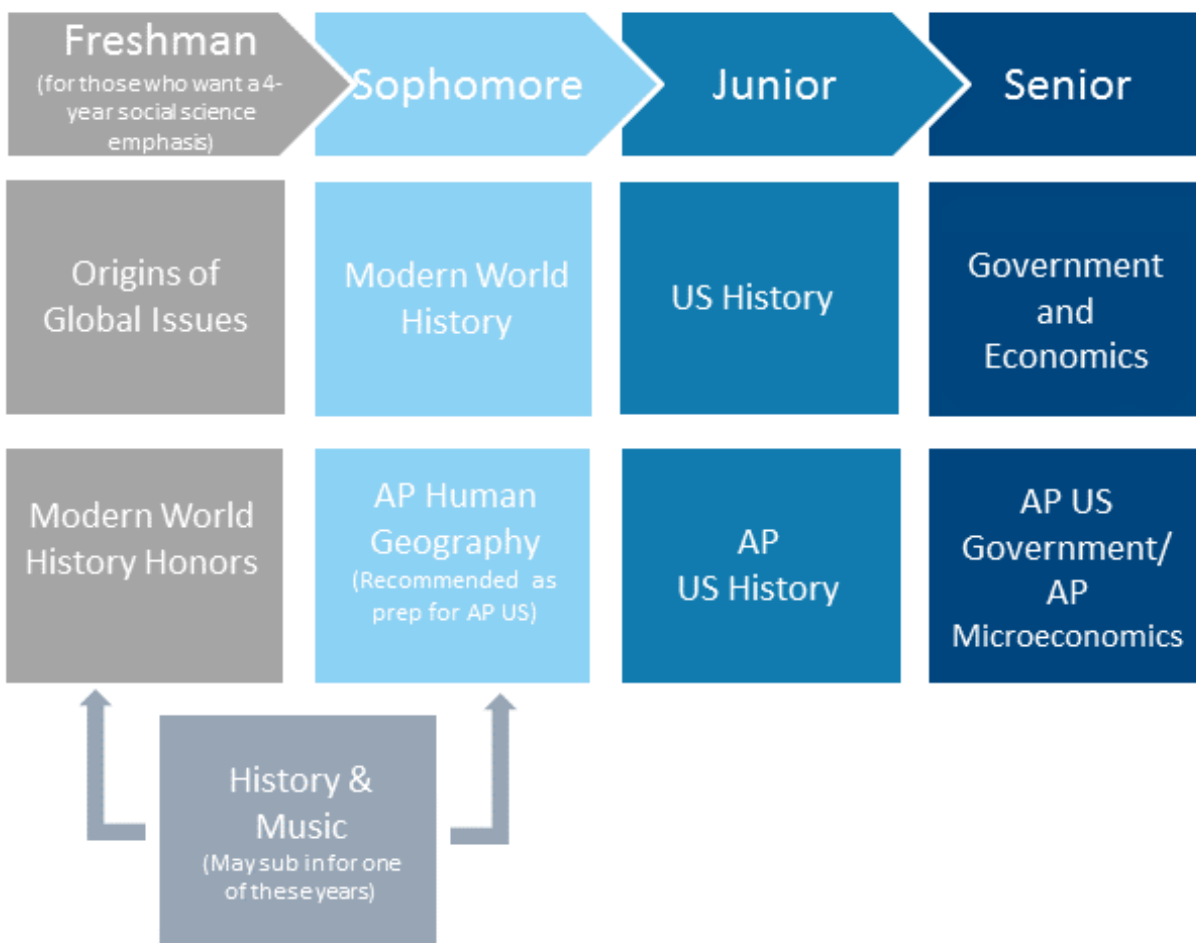

This map is intended as a general planning tool that shows the typical tracks students at VCHS follow. Students can deviate from the map and should consult with their counselors and teachers to find the best social science courses to meet their academic goals.

AMSE MAJOR/MINOR REQUIREMENTS

The Applied Math, Science, and Engineering (AMSE) Institute offers VCHS students the opportunity to specialize and participate in a robust array of STEM courses and co-curricular activities. This program offers unique training with experienced professionals to aid students in developing a competitive portfolio of work throughout high school. VCHS AMSE students have extraordinary opportunities to enter elite competitions, participate in an International Space Station project, conduct research in our state-of-the-art Bio Safety Lab, complete advanced work in our NanoTechnology/Microscopy Lab, observe the heavens through our Schmidt-Cassegrain telescope, and much more. The curriculum for the AMSE program is designed to advance the unique interests and abilities of the individual and provides opportunities for students to enhance their classroom knowledge through real world application. AMSE students receive mentoring and guidance regarding the courses and activities that will best assist them in meeting personal goals. For more information, contact: AMSE@vcs.net.

AMSE MAJORS MUST COMPLETE THE FOLLOWING

- 1 AMSE Science Research Project
- Attend 8 Seminars
- Third level of World Language
- 4 years of an AMSE Co-curricular
- 4 years of Mathematics
- 3 years of Science
- Additional AMSE electives, such as [Life Calling in the Workplace](#), recommended
- Highlands Ability Test highly recommended

AMSE MINORS MUST COMPLETE THE FOLLOWING

- Attend 5 Seminars
- Second level of World Language
- 4 years of an AMSE Co-curricular
- 4 years of Mathematics
- 3 years of Science
- Additional AMSE electives, such as [Life Calling in the Workplace](#), recommended
- Highlands Ability Test highly recommended

CONSERVATORY MAJOR/MINOR REQUIREMENTS

VCHS offers an exciting opportunity for high school students to further refine their God-given artistic talents with a major or minor in one of eight disciplines:

- Music
- Visual Arts
- Dance Arts
- New Media Studies
- Theatre Arts
- Musical Theater
- Integrated Arts
- Theatrical Design and Technology

Students may apply to join one of these exceptional programs and, upon acceptance, receive comprehensive training through a personalized, flexible schedule. The program is designed to provide inspiring experiences that engender a lifelong passion for the arts, alongside rigorous academics to support the student's personal *Quest for Excellence™*. For more information, contact Vicki Wagner, Conservatory Student Services, at vwagner@vcs.net.

CONSERVATORY MAJORS MUST COMPLETE THE FOLLOWING MINIMUM (LAST UPDATED 2016)

- 80 units of discipline-specific Conservatory coursework as designated by program leaders (performance courses, technique courses, general art courses, etc.)
- Discipline-specific extracurricular requirements as designated by program leaders (private lessons, portfolio submissions, main stage theatre, dance performances, etc.)

CONSERVATORY MINORS MUST COMPLETE THE FOLLOWING MINIMUM

- 40-50 units (varies by discipline) discipline-specific Conservatory coursework (see program requirements)
- Discipline-specific extracurricular requirements as designated by program leaders (private lessons, portfolio submissions, main stage theatre, dance performances, etc.)

For Conservatory Major and Minor requirements in each discipline, please see the online [Conservatory Major/Minor Graduation Requirements](#).

COURSE REMEDIATION POLICIES

Since Valley Christian High School has such diverse and unique course offerings, students must be very careful to enroll in courses that match their academic abilities.

- If a student does not drop the course before the published drop date, the grade will be recorded on the student transcript. Once a grade is on the transcript, it cannot be removed.

- Only grades of a 69% or lower will have a grade replacement option in the GPA.

Valley Christian High School and the vast majority of colleges, use the remediated grade to calculate GPA when the original grade was 69% or lower. Some colleges that do not follow this practice and instead take the average of the D/F and the remediated grade. Valley Christian, following the common college model, will not recalculate the GPA when the original grade was 69% or higher.

If a student remediates the course, the transcript will show that the course was taken twice. This can show colleges a student's perseverance and ability to learn from an academic mistake.

Students who retake the course can only replace the grade in the GPA calculation with the EXACT same course. Valley Christian cannot guarantee that there will be a summer school option to remediate a course, particularly for honors, AP, and elective courses. **For example, Valley Christian does not offer a summer school Biology Honors option, and a student could only remediate that grade by retaking the course during the school year or at a community college.** Students who remediate may have to take the course again with the same teacher, so please use historical academic performance, wisdom, and counselor advice when considering an honors track.

Students seeking an exact match through a community college or another institution must have approval from their academic counselor prior to enrollment.

FOR COMPLETION OF GRADUATION REQUIREMENTS

If a student fails a course required for a Valley Christian diploma, the course will have to be remediated. In general, students cannot be promoted to the next level of a content area unless they pass the previous course.

FOR COLLEGE ADMISSION

Students who earn a 69% or lower in an academic course should remediate the course for their best college options. UCs will not allow a D to even be recorded on an application. If a student earns a D in a Bible course or non-college prep course, it can stay on the transcript, but it will negatively impact the overall GPA. The safest course of action is to remediate all Ds.

Some colleges allow a first semester D in math and foreign language to be "validated" by earning a C or higher in the second semester, but colleges do change policies. Students should always check with their academic counselor before attempting to remediate a grade.

TRANSCRIPT POLICIES

Your high school transcript is your official high school record. The transcript is probably the most important source of information for college admissions. It lets colleges not only see your grades, but it lets them review what types of courses you took. It is important to ensure that this is an accurate record of your high school performance. Please review your transcript for accuracy and contact the registrar, Christine Baxter, at cbaxter@vcs.net if you have any questions or concerns.

Valley Christian High School includes courses taken at Valley Christian on the student transcript. Courses taken for enrichment will not be added to the school transcript. Courses that qualify under the remediation policies will be added to the transcript.

VCHS HOMEWORK EXPECTATIONS

Research shows that homework at the high school level is linked to college readiness and is needed for the development of student academic behavior such as time management, study skills, persistence, and help-seeking behaviors. Students are expected to practice the above skills and set aside distraction-free time each night to focus on their academic development. When planning their schedules, students should remember that different courses require different amounts of homework and effort outside of the school day. In addition to homework, students often choose to be involved in one or more extracurricular activities.

AVERAGE HOMEWORK COMMITMENT

- | | |
|-----------------------------|--|
| 1. <i>AP/Honors Courses</i> | 1 hour per course meeting |
| 2. <i>Regular Courses</i> | ½ hour per course meeting (45 minutes for math) |

Because every student is unique, as students calculate the amount of time they will dedicate to their school work and other activities, they can adjust the homework expectations based on their previous experiences.

AVERAGE EXTRACURRICULAR COMMITMENT

- | | |
|------------------------------------|---|
| 3. <i>Sports</i> | 15-18 hours per week |
| 4. <i>Band/Theatre/Dance</i> | These outside activities require <u>major</u> time commitments during certain parts of the year. |
| 5. <i>Community Service/Church</i> | Time varies |

Students may use the following worksheet to calculate the amount of time that their academic and extracurricular commitments will require. It is important for families to take into account sufficient time for sleep, family, church activities, friendships, etc. **Parents can help their students prioritize how they should be spending their time, and the academic counseling department is available to help assist families in planning schedules that will provide the appropriate academic rigor to prepare students for college and career success as well as a balanced, healthy life.**

TIME COMMITMENT WORKSHEET

COURSE SELECTION PLANNER

Course	Average Homework Per Course Meeting	Average Homework Per Week
1.	___ hours	___ hours
2.	___ hours	___ hours
3.	___ hours	___ hours
4.	___ hours	___ hours
5.	___ hours	___ hours
6.	___ hours	___ hours
7.	___ hours	___ hours
8.	___ hours	___ hours
Each week night =		___ hours
=		___ hours
___ hours		

SAMPLE STUDENT SCHEDULE

Course	Average Homework Per Course Meeting	Average Homework Per Week
Open Period	0 hours	0 hours
Spanish III Honors	1 hour	2-3 hours
AP Calculus BC	1 hour	2-3 hours
AP Biology	1 hour	2-3 hours
AP US History	1 hour	2-3 hours
AP English Language and Composition	1 hour	2-3 hours
Digital Journalism I	½ hour	1-1½ hours
Biblical Leadership	½ hour	1-1½ hours
Each week night =		14-16 hours
3-4 hours		

TIME PLANNER

Activity	Hours Per Day	Hours Per Week
Breakfast	___ hours	___ hours
Time in School	7 hours	35 hours
Travel Time	___ hours	___ hours
Extracurricular(s)	___ hours	___ hours
Dinner	___ hours	___ hours
Homework	___ hours	___ hours
Free time	___ hours	___ hours
Family time	___ hours	___ hours
Church/Youth Group	___ hours	___ hours
Volunteer Work	___ hours	___ hours
Sleep	9.5 hours	66.5 hours
Total	24 hours	168 hours

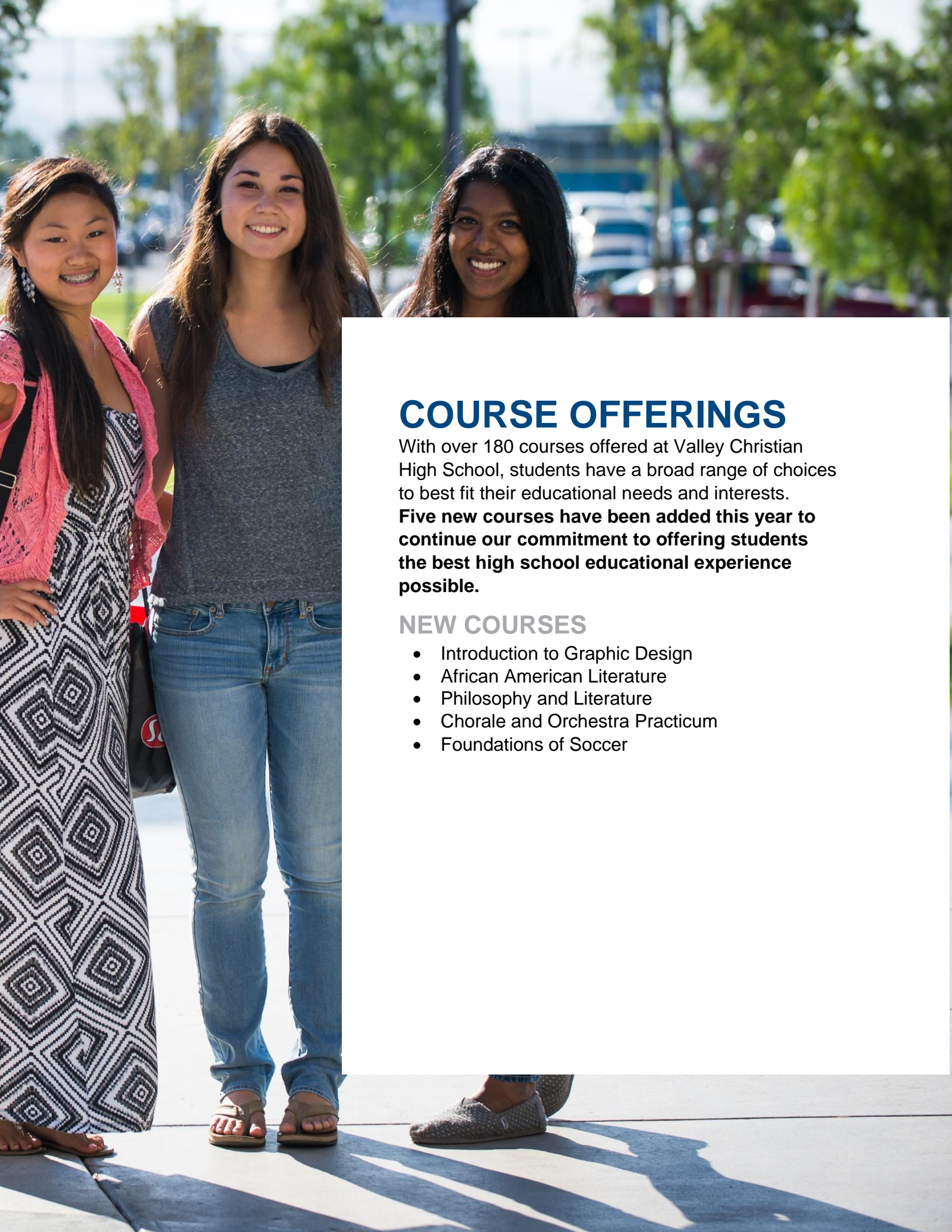

COURSE OFFERINGS

With over 180 courses offered at Valley Christian High School, students have a broad range of choices to best fit their educational needs and interests.

Five new courses have been added this year to continue our commitment to offering students the best high school educational experience possible.

NEW COURSES

- Introduction to Graphic Design
- African American Literature
- Philosophy and Literature
- Chorale and Orchestra Practicum
- Foundations of Soccer



VCCHS DUAL CREDIT COURSES

These offerings are courses taught by a VCCHS faculty member who serves as an adjunct professor at a partner college. The course is taught during the regular VCCHS day and recorded on both the VCCHS transcript and the college/university transcript with a letter grade assigned. This allows a student a chance to receive college credit while attending high school.

DUAL CREDIT PROGRAM POLICIES

- Courses listed in the Course Catalog as dual credit are possible offerings. Final offerings may be changed based on the level of student interest and final master schedule decisions.
- Once a dual credit student is enrolled at the partner college as a college student, he/she must adhere to that college's policies. Dual credit college policies, such as add/drop and W/F deadlines, cannot be modified by VCHS.
- After a student is officially enrolled in the dual credit course(s), VCHS will not issue refunds.
- **Students must keep track of which courses they have taken for dual credit and from which institution.** Students must inform their VCHS academic counselor of their dual credit courses when completing college applications in order to maximize the program's benefits.
- It is the student's responsibility to notify the counselor if he/she is currently enrolled in a course for dual credit and is requesting to move from the dual credit course to another teacher or course. **Students transferring to another course after enrolling as a dual credit student may receive a W/F on the college transcript.**
- Students must keep records of their college student ID and confirmation of enrollment in dual credit. Students will need this information for several years.
- The VCHS grade earned by a student enrolled in a dual credit course will be recorded on the college transcript and preserved permanently on the student's academic record.
- Once a senior has committed to a college/university to attend after high school, he/she is responsible for sending the dual credit transcript to that college/university to verify the dual credit courses reported on the college/university application. **Failure to do this could result in a college/university withdrawing their admissions offer.**
- VCHS does not guarantee that dual credit college credits will transfer to the student's college/university of choice and will do its best to advise parents and students on the likelihood of transferability.

POLICIES SPECIFIC TO WEST HILLS COMMUNITY COLLEGE

- West Hills does not automatically send out transcripts; they must be ordered by the student through the West Hills online system. VCHS strongly recommends that students order a transcript after each semester to verify its accuracy. It is the student's responsibility to ensure his/her academic record is correct.
- West Hills College uses a different grading scale than VCHS. West Hills College does not record pluses or minuses.
- For year-long courses, the student's first and second semester percentage grades are averaged for their final grade.
- Every senior taking a West Hills Community College course must take the final exam, even if he/she has a second semester grade of A.
- Course sizes are limited to 50 students per WHCC section, so sign-ups are taken on a first come basis.
- If there are not enough student sign-ups to offer the course, students and parents will be notified that the offering has been collapsed, and the checks will be returned.

2018-2019 DUAL CREDIT OFFERINGS

This list is based on anticipated course offerings and will be finalized and released in the August 2017 parent newsletter.

SUBJECT	VCHS COURSE	LENGTH OF COURSE	DUAL CREDIT COLLEGE	COURSE EQUIVALENT	USEFUL NOTES*	# OF UNITS
Bible	Ethics	Fall and Spring Semesters	Colorado Christian	PHIL 214 (Ethical Issues)	Transfer determined by each college. If accepted, it fulfills Humanities. Dual credit can help college admissions (non-UC approved course).	3
	Intro to Life Calling	Fall and Spring Semesters	Ohio Christian University	LDR 150	Transfers as elective credits <i>IWU uses a slightly different grading scale.</i>	3
	Philosophy of Religion	Fall and Spring Semesters	West Hills College	PHIL 2 (Intro to Logic)	Transfers as CSU GE: Critical Thinking Dual credit can help college admissions (non-UC approved course).	3
	Philosophy of Religion	Fall and Spring Semesters	Colorado Christian	PHIL 260 (Christian Apologetics)	Transfer determined by each college. If accepted, it fulfills Humanities. Dual credit can help college admissions (non-UC approved course).	3
	World Religions	Spring Semester	West Hills College	PHIL 1	Transfers as CSU GE: Humanities	3
Tech. & Bus.	Debate	Spring Semester	West Hills College	COM 3	Transfers as CSU GE: Oral Communication OR Critical Thinking Dual credit can help college admissions (non-honors course).	3

SUBJECT	VCHS COURSE	LENGTH OF COURSE	DUAL CREDIT COLLEGE	COURSE EQUIVALENT	USEFUL NOTES*	# OF UNITS
	Speech	Fall Semester	Colorado Christian	COM 103	Transfers as CSU GE: Oral Communication Dual credit can help college admissions (non-honors course).	3
English	AP English Literature	Year Long	Colorado Christian	ENG 102	Transfers as CSU GE: Written Communication OR Critical Thinking	3
	Early British Literature	Fall Semester	Colorado Christian	ENG 204	Transfer determined by each college. If accepted, it <u>might</u> fulfill Written Communication	3
	Early/Late British Literature	Spring Semester	Colorado Christian	ENG 205	Transfer determined by each college. If accepted, it <u>might</u> fulfill Written Communication	3
	English 11	Year Long	Colorado Christian	ENG 203 (American Literature)	Transfer determined by each college. If accepted, it <u>might</u> fulfill Written Communication	3
Mathematics	AP Calculus AB	Year Long	Williams Jessup	MATH 140	Transfers as CSU GE: Quantitative Reasoning	5
	AP Statistics	Year Long	Colorado Christian	MAT 212	Transfers as CSU GE: Quantitative Reasoning	4
	AP Calculus BC	Year Long	William Jessup	MATH 141	Transfer determined by each college. If accepted, it fulfills Quantitative Reasoning. Dual credit can help college admissions (non-honors course).	4

SUBJECT	VCHS COURSE	LENGTH OF COURSE	DUAL CREDIT COLLEGE	COURSE EQUIVALENT	USEFUL NOTES*	# OF UNITS
	Honors Trigonometry/ Pre-Calculus BC	Year Long	West Hills College	MATH 15	Transfers as CSU GE: Quantitative Reasoning	5
	Multivariable Calculus	Year Long	William Jessup	MATH 242	Transfers as CSU GE: Quantitative Reasoning Dual credit can help college admissions (non-UC honors course).	4
Science	AP Biology	Year Long	Colorado Christian	BIO 101/111	Transfer determined by each college. If accepted, it would fulfill Life Sciences.	4
	AP Chemistry	Year Long	Colorado Christian	CHEM 122/132	Transfer determined by each college. If accepted, it would fulfill Physical Sciences.	4
	AP Environmental Science	Year Long	Colorado Christian	PHY 105/106	Transfer determined by each college. If accepted, it would fulfill Physical Sciences.	4
	Astronomy	Year Long	William Jessup	SCI 122	TBD	
	Honors Anatomy and Physiology	Year Long	West Hills College	BIO 35	Transfers as CSU GE: Life Science	4
	Honors Biology	Year Long	West Hills College	BIO 10	Transfers as CSU GE: Life Science	3
	Honors Chemistry	Year Long	Colorado Christian	CHEM 121/131	Transfer determined by each college. If accepted, it would fulfill Physical Sciences.	4

SUBJECT	VCHS COURSE	LENGTH OF COURSE	DUAL CREDIT COLLEGE	COURSE EQUIVALENT	USEFUL NOTES*	# OF UNITS
	AP United States Government	Fall Semester	Colorado Christian	POL 207	Transfers as CSU GE: American History or Social Science	3
	AP United States History	Fall Semester	Colorado Christian	HIS 205	Transfers as CSU GE: Humanities, American History, or Social Science	3
Visual Arts	AP Studio Art: 2D	Year Long	William Jessup	CART260	TBD	
	AP Studio Art: Drawing	Year Long	William Jessup	CART165	TBD	
	Ceramics	Year Long	West Hills College	ART13A	Transfers as CSU GE: Arts (<i>studio art will not count for UC IGETC</i>)	3
	French IV Honors	Year Long	Colorado Christian	FRE 201 (Intermediate French)	Transfer determined by each college. If accepted, it would fulfill Humanities.	3



VCHS ADVANCED PLACEMENT AND HONORS COURSES

Valley Christian High School is committed to offering our students academically challenging courses in order to prepare them for any college environment. One avenue to reach courses of college-level rigor is through our Advanced Placement (AP) courses. The 2018 fee for taking each AP exam is \$94. With a passing score on the exam, students may receive college credit.

The VCHS AP program prepares students for 23 AP exams, including:

- AP Computer Science
- AP English Language
- AP English Literature
- AP Chinese Language & Culture
- AP Latin
- AP Spanish Language & Culture
- AP Statistics
- AP Calculus AB
- AP Calculus BC
- AP Music Theory
- AP Biology
- AP Chemistry
- AP Environmental Science
- AP Physics 1
- AP Physics C: Mechanics
- AP Physics C: Electricity & Magnetism
- AP Human Geography
- AP US History
- AP Microeconomics
- AP US Government & Politics
- AP Studio Art: 2D Design
- AP Studio Art: Drawing
- AP Art History

In addition to the AP program, VCHS offers the following 20 honors courses:

- Dance Technique III Honors
- English 9 Honors*
- English 10 Honors*
- Geometry Honors*
- Algebra II Honors*
- Trig/Pre-Calc BC Honors
- Multivariable Calculus*
- Advanced Data Analysis*
- Advanced Business Honors
- Jazz Ensemble Honors
- Biology Honors*
- Chemistry Honors
- Anatomy & Physiology Honors
- Modern World History Honors*
- Theatre II Honors
- Technical Theatre II Honors
- Chinese (Mandarin) IV Honors
- French IV Honors
- Latin IV Honors
- Spanish III Honors

*Though internal honors credit is given, the UC does not calculate an honors grade point for this course. Other colleges may assign honors credit.

VCHS APPROVED A-G COURSES FOR UNIVERSITY OF CALIFORNIA & CALIFORNIA STATE UNIVERSITY

A – HISTORY

Origins of Global Issues
Modern World History
Modern World History Honors*

U.S. History
AP United States History
US Government

AP Government & Politics (U.S.)
History and Music
AP Human Geography

B – ENGLISH

English 9
English 9 Honors*
English 10
English 10 Honors*

American Literature
Sports in Literature & Writing
AP English Language & Composition
Early British Literature

Late British Literature
AP English Literature & Composition

C – MATHEMATICS

Algebra I
Geometry
Geometry Honors*
Algebra II
Algebra II Honors*

Finite Math
Trigonometry/Pre-Calculus
Trig/Pre-Calculus Honors (BC)
Statistics
AP Statistics

Calculus
AP Calculus AB
AP Calculus BC
Multivariable Calculus*
Advanced Data Analysis

D – LABORATORY SCIENCE

Biology I (CSU Life Sci)
Biology I Honors* (CSU Life Sci)
Marine Biology**
Anatomy & Phys. (CSU Life Sci)
Anatomy & Physiology Honors

AP Biology (CSU Life Sci)
Chemistry (CSU Phy Sci)
Chemistry Honors (CSU Phy Sci)
AP Chemistry (CSU Phy Sci)
Physics (CSU Phy Sci)

AP Physics 1
AP Physics C: Mechanics/E&M (CSU Phy Sci)
AP Environmental Science
Astronomy
Integrated Science

E – Language Other Than English (LOTE)

American Sign Language I
American Sign Language II
American Sign Language III
French I
French II
French III
French IV Honors
Latin I

Latin II
Latin III
Latin IV Honors
AP Latin
Spanish I
Spanish II
Spanish III
Spanish III Honors

Spanish IV
AP Spanish Language & Culture
Chinese (Mandarin) I
Chinese (Mandarin) II
Chinese (Mandarin) III
Chinese (Mandarin) IV Honors
AP Chinese Language & Culture

*Though internal honors credit is given, the UC does not calculate an honors grade point for this course. Other colleges may assign honors credit. **Earned internal honors credit 2014-2015 and prior years.

F – VISUAL/ PERFORMING ARTS

The Art of Filmmaking	Jazz Lab	Art I
3D Film Animation	Jazz Ensemble Honors	Art II
Advanced 3D Animation	String Ensemble	Art III
Ballet II	Percussion Ensemble	AP Studio Art: Drawing
Dance Technique I	Piano I	AP Studio Art: 2D Design
Dance Technique II	Piano II	Photographic Design I
Dance Technique III	Piano III	Photographic Design II
Dance Technique III Honors	Women's Vocal Ensemble	Photographic Design Studio
Tap I	Vocal Jazz Ensemble	Music Technology
Tap II	Worship Band (Choir)	Ceramics
Tap III	Theatre I	Ceramics II
Hip Hop I	Theatre II	Intro to Guitar and Electric Bass
Hip Hop II	Theatre II Honors	Guitar II
Hip Hop III	Musical Theatre	Guitar III
Symphonic Band	Technical Theatre I	Applied Filmmaking
Wind Ensemble	Technical Theatre II	AP Art History
AP Music Theory	Technical Theatre II Honors	

G – ELECTIVE COURSES

Economics	Digital Electronics (PLTW)	World Religions
AP Microeconomics	Speech	Introduction to Computer
AP Computer Science A	Debate	Programming
Principles of Engineering (PLTW)	Journalism I (10-12 grade)	Introduction to Entrepreneurship
Introduction to Engineering (PLTW)	Journalism II	Advanced Business Honors
Aerospace Engineering (PLTW)		

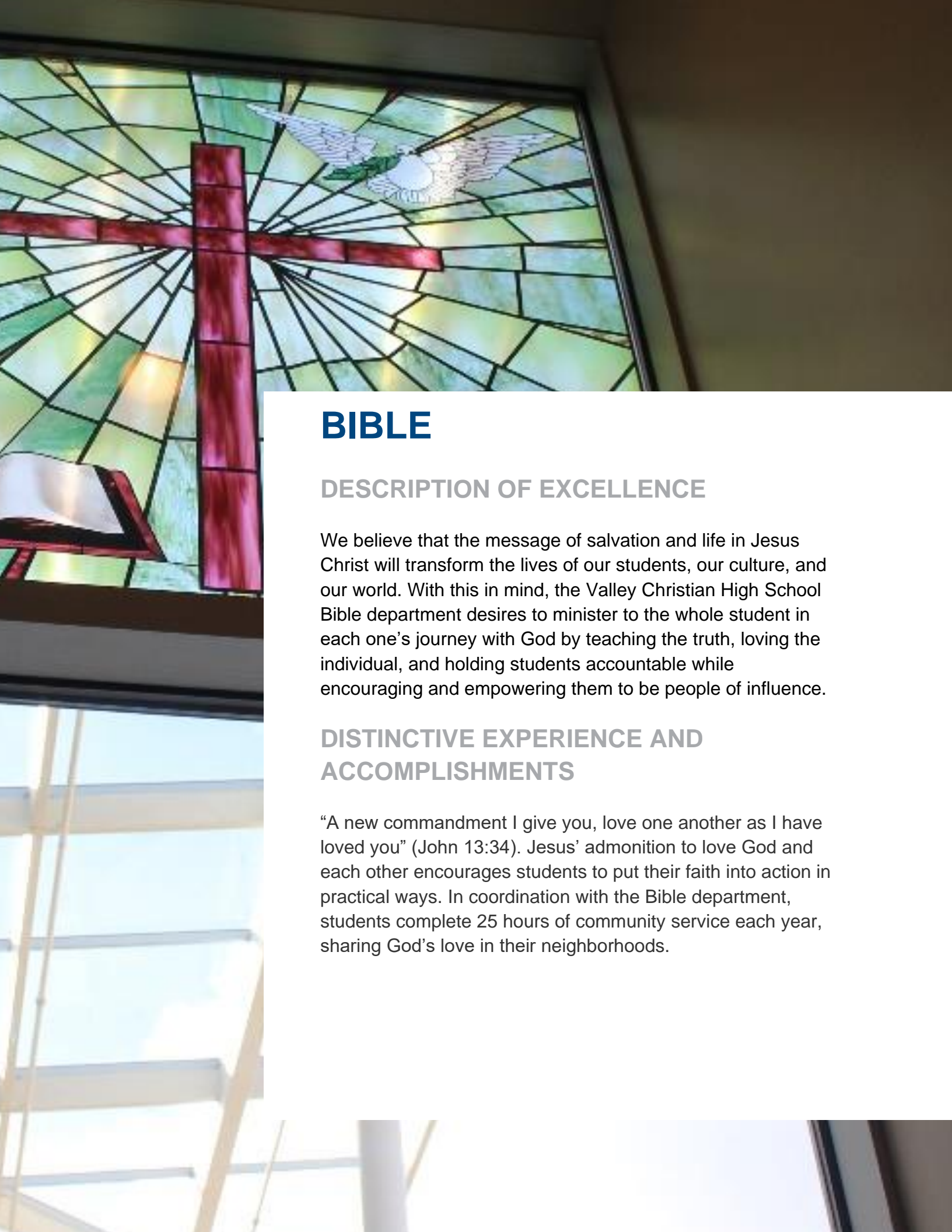

BIBLE

DESCRIPTION OF EXCELLENCE

We believe that the message of salvation and life in Jesus Christ will transform the lives of our students, our culture, and our world. With this in mind, the Valley Christian High School Bible department desires to minister to the whole student in each one's journey with God by teaching the truth, loving the individual, and holding students accountable while encouraging and empowering them to be people of influence.

DISTINCTIVE EXPERIENCE AND ACCOMPLISHMENTS

"A new commandment I give you, love one another as I have loved you" (John 13:34). Jesus' admonition to love God and each other encourages students to put their faith into action in practical ways. In coordination with the Bible department, students complete 25 hours of community service each year, sharing God's love in their neighborhoods.



BIBLE COURSES OFFERED

Semester Courses (already paired together)

- Foundations of Christianity
- New Testament Studies
- Biblical Literature/Spiritual Disciplines
- Introduction to Life Calling/Applied Ethics
- Philosophy of Religion/World Religions
- Life Calling in The Workplace
- The Truth Project/Spiritual Disciplines -Online

Leadership & Outreach Courses

- Biblical Leadership*
- Missions*
- ASB Biblical Government*
- Community Outreach*
- Arts Outreach*
- Christian Athletic Leadership*
- Advanced Biblical Leadership*
- Advanced Community Outreach*

Community Service Requirement

The Valley Christian High School community service requirement is an integral part of all Bible courses. Ten hours must be completed prior to the end of the first semester, and the remaining 15 hours must be completed prior to the end of the second semester.

Ten hours must be completed with a Christ-centered church and the remaining 15 hours may be completed with a nonprofit organization or a Christ-centered church.

* Some upper division Bible courses require instructor approval to enroll. The Bible department provides directions for application in the spring. Consideration for enrollment typically involves an interview along with the application.

FOUNDATIONS OF CHRISTIANITY

Course Number	TBD
Grade Level	9
Pre-Requisite	<i>This course is required for students not coming from a Christian background in order to build a foundation for future Bible courses.</i>
Application and/or Audition Date	None
Grade Scale	Standard
Credits	5/5
VCHS Graduation Credit	Bible
UC Approval	None
Fees	None

Freshmen with a strong Bible foundation have the opportunity to omit the traditional first year of Bible (Foundations of Christianity) and move directly to the sophomore year (New Testament Studies). New Testament Studies provides a rich exposure to critical biblical doctrine (material not covered by VCJH). After gaining this foundation, these students move on to an upper division Bible course, thereby allowing students with years of biblical training to quickly move beyond the Bible basics and gain access to more focused biblical study and application during their high school experience.

COURSE DESCRIPTION

This course probes the great questions of the Christian faith in the context of our post-modern culture. Questions such as, “Is Christ the only way to God?”, “Does the Bible speak to us today?”, and “Is all truth relative?” challenge students to examine their own views of God. This course strives to help students compare the difference between cultural concepts of God and a Biblical understanding of God.

This course also develops biblical study skills by teaching students to extract meaning from biblical passages, in the context of exploring who God is and who we are. Students also learn how to apply these biblical principles to their own lives. An emphasis is placed on how stories in the Bible foreshadow and point towards the need for the savior: Jesus Christ.

NEW TESTAMENT STUDIES

Course Number	0314
Grade Level	9, 10
Pre-Requisite	<i>This course is designed for students entering VCHS with a strong Biblical foundation (at least 2 years of previous Bible courses and/or at least 4 years in Christian church courses) or as a course following Foundations of Christianity.</i>
Application and/or Audition Date	None
Grade Scale	Standard
Credits	5/5
VCHS Graduation Credit	Bible
UC Approval	None
Fees	None

COURSE DESCRIPTION

New Testament Studies

This course examines the New Testament letters starting with the book of Matthew and extending through the book of Acts. Students study the historical and cultural significance surrounding the life of Christ and the beginning of the Christian church. By analyzing the works and teachings of Jesus, students see how those impacted the first century and modern Christianity. This course is broken into five teaching units: the Bible, God, Jesus, Jesus' death, and the church.

This course also examines selected New Testament letters and doctrines. Students study the historical context of the New Testament and how it can change lives in today's culture. They compare and contrast our culture with what scripture says about the nature of reality, how to endure in trying times, and how to develop and maintain healthy relationships.

Freshmen with a strong Bible foundation have the opportunity to omit the traditional first year of Bible (Foundations of Christianity) and move directly to the sophomore year (New Testament Studies). After one semester to refresh knowledge of New Testament History, students dive into New Testament Literature, which provides a rich exposure to critical biblical doctrine (material not covered by VCJH). After gaining this foundation, these students move on to an upper division Bible course, thereby allowing students with years of biblical training to quickly move beyond the Bible basics and gain access to more focused biblical study and application during their high school experience.

BIBLICAL LITERATURE/SPIRITUAL DISCIPLINES

Course Number	0339
Grade Level	10, 11, 12
Pre-Requisite	None for 11th and 12th graders. 10 th graders must have taken NT Literature and History.
Application and/or Audition Date	None
Grade Scale	Standard
Credits	5/5
VCHS Graduation Credit	Bible
UC Approval	None
Fees	None

COURSE DESCRIPTION

Biblical Literature

This course's purpose is to inform students on the diverse types of literature and interpretation methods used in studying the Bible in order for them to approach Bible study with greater insight. After an overview of the types of literature and interpretation methods, students will apply this knowledge to a study in some of the Old Testament Wisdom Literature. The course culminates in a final project where students choose their own portion of scripture to analyze and interpret using the skills they have developed over the course of the semester.

Spiritual Disciplines

This course trains students in the disciplines of the Christian faith by guiding students to adopt the following spiritual habits before entering a university setting: 1) The Inward Disciplines (meditation, prayer, fasting, study); 2) The Outward Disciplines (simplicity, solitude, submission, service); and 3) The Corporate Disciplines (confession, worship, guidance, celebration). The main text is *Celebration of Discipline* by Richard Foster, with supplemental material from Dallas Willard.

INTRODUCTION TO LIFE CALLING/APPLIED ETHICS

Course Number	0346
Grade Level	11, 12
Pre-Requisite	None
Application and/or Audition Date	None
Grade Scale	Standard
Credits	5/5
VCHS Graduation Credit	Bible
UC Approval	None
Fees	\$25

COURSE DESCRIPTION

Introduction to Life Calling

This course focuses on discovering students' life purpose and calling as the context for making decisions and gaining direction for their lives. Students explore their own foundational values, unique design, and personal mission as the most effective approach to gaining an understanding of life purpose and calling. A key component of this course concentrates on the discovery of one's God-given strengths, passions, and experiences as a basis for this calling.

Applied Ethics

This course answers the essential question, "Is God good?" Students compare the law as expressed in the Torah to the teachings of Jesus and Paul in the New Testament in order to answer questions including the following: "Does God's standard of morality change from the Old Testament to the New Testament?", "What is the purpose of the detailed laws in the Old Testament if we are saved by faith?", and "Why should we think that the Bible can inform our moral decisions today?" Students are also challenged to study modern day moral issues through the lens of Jesus' representation of morality.

PHILOSOPHY OF RELIGION/WORLD RELIGIONS PAIRING

The semester-long courses Philosophy of Religion and World Religions are paired. Students who enroll in Philosophy of Religion will automatically be enrolled in World Religions.

PHILOSOPHY OF RELIGION

Course Number	0325
Grade Level	11, 12
Pre-Requisite	None
Application and/or Audition Date	None
Grade Scale	Standard
Credits	5/5
VCHS Graduation Credit	Bible
UC Approval	None
Fees	Dual Credit fees

COURSE DESCRIPTION

Philosophy of Religion serves as an introduction to logic and also answers the question, "Are there good reasons to believe any religion (specifically Christianity) is actually true?" The goal of this course is for students to use appropriate philosophical logic in giving a culturally relevant, sound, and objective defense of their beliefs. Students achieve this through examining the basics of logic itself, recent arguments for and against the existence of God, the resurrection of Jesus, the historical accuracy of the Bible, and other major topics relating to Christian truth. Challenging students to consider how issues of character and communication may help or hinder the defense of their belief, this course also lays the philosophical foundation for asking the same difficult questions of other religions in the course World Religions.

WORLD RELIGIONS

Course Number	0350
Grade Level	11, 12
Pre-Requisite	Philosophy of Religion
Application and/or Audition Date	None
Grade Scale	Standard
Credits	5
VCHS Graduation Credit	Bible
UC Approval	Yes, Semester – Area G (General Elective – History/Social Science)
Fees	Dual Credit fees

COURSE DESCRIPTION

World Religions is designed to give students the structure to help organize their thoughts and enable them to make intelligent judgments about different philosophical claims. It focuses on the major world religions and how each answers philosophical questions related to the meaning of life. Some of the questions included relate to views on ethics, the nature of the external world, the nature of man, the role of the mind, and views of knowledge. Students are introduced to each faith through their texts and by advocates of each tradition (via pre-recorded interviews). They then have the opportunity to evaluate the philosophical claims of each religion through discussions, essays, and their final project.

LIFE CALLING IN THE WORKPLACE

Course Number	0365
Grade Level	11, 12
Pre-Requisite	None
Application and/or Audition Date	Priority for limited space in this course will be given to AMSE students.
Grade Scale	Standard
Credits	5/5
VCHS Graduation Credit	Bible
UC Approval	None
Fees	\$25 + Dual Credit Fee

COURSE DESCRIPTION

Introduction to Life Calling

This course focuses on discovering students' life purpose and calling as the context for making decisions and gaining direction for their lives. Students explore their own foundational values, unique design, and personal mission as the most effective approach to gaining an understanding of life purpose and calling. A key component of this course concentrates on the discovery of one's God-given strengths, passions and experiences as a basis for this calling.

Life Calling in the Workplace

"Do you see a man skilled in his work? He will serve before kings." (Prov. 22:29)

"Excellence Brings Influence" is a fundamental value in transforming the world for the Kingdom of God. In order for us to impact the world for Jesus Christ we must view our work as an act of worship and ministry. In light of these truths, this course seeks to create an environment in which students can strategically explore how their faith will integrate into a college, business, and industry setting. Key components of this course are based upon Fuller Youth Institutes' *Sticky Faith* research. Students are also introduced to the model of "Prayer Evangelism" as a practical way to bring the light of the Gospel into their college and workplace.

ONLINE COURSES

The following course can be taken online. Online courses are recommended for students with scheduling conflicts, those who need to make up missing units.

THE TRUTH PROJECT/SPIRITUAL DISCIPLINES - ONLINE

Course Number	0323x/0332x
Grade Level	11, 12
Pre-Requisite	Counselor approval
Application and/or Audition Date	None
Grade Scale	Standard
Credits	10
VCHS Graduation Credit	Bible
UC Approval	None
Fees	None

COURSE DESCRIPTION

The Truth Project

Building systematically with each lesson, this course presents a comprehensive Biblical worldview for students to consider. Consisting of thirteen informative videos produced by Focus on the Family that challenge how each student views the world, this course culminates in a comprehensive research paper based on the material from the video series.

Spiritual Disciplines

Students are trained in the disciplines of the Christian faith. This course guides students to adopt the following spiritual habits before entering the university setting: 1) "The Inward Disciplines" (meditation, prayer, fasting, study); 2) "The Outward Disciplines" (simplicity, solitude, submission, service); and 3) "The Corporate Disciplines" (confession, worship, guidance, celebration). The main text is *Celebration of Discipline* by Richard Foster, with supplemental material from Dallas Willard.

Additional Expectations: These courses typically require three hours of homework per week and up to twenty pages of reading per week; they also include online instruction and resources. Students enrolled in this course must have internet access at home. Homework assignments must be submitted via the internet.

LEADERSHIP AND OUTREACH COURSES

The following year-long courses are offered for those students who want to outwardly express their faith in Christ through servant leadership and/or evangelistic outreach. Each of these courses requires an application and instructor approval.

BIBLICAL LEADERSHIP

Course Number	0312
Grade Level	11, 12
Pre-Requisite	Application and instructor approval
Application and/or Audition Date	February 9
Grade Scale	Standard
Credits	10
VCHS Graduation Credit	Bible
UC Approval	None
Fees	\$60

COURSE DESCRIPTION

This year-long course educates students on the principles of leadership in an activities based setting. Students are shown the methods ordinary people use to bring forth the best in themselves and others. Students weave together faith and learned principles and explore how Christian leaders can apply each leadership method. The four units include “Self-Leadership: We must lead ourselves before leading others,” “Connecting with Others: We must know and understand others before we lead them,” “Leading Others: How do we influence those around us effectively?” This course gives students the knowledge and resources to hold leadership positions in school, church, and community. Leading the Freshman Mentoring program is a key component of this course.

Additional Expectations: This course requires a minimum of 30 hours per semester of volunteer work outside of course.

MISSIONS

Course Number	0322
Grade Level	11, 12
Pre-Requisite	<i>Application and instructor approval</i>
Application and/or Audition Date	February 9
Grade Scale	Standard
Credits	10
VCHS Graduation Credit	Bible
UC Approval	None
Fees	<i>See Additional Expectations</i>

COURSE DESCRIPTION

This year-long course trains students to assess and minister to the needs of a culture/community. Students are empowered to share their personal faith in a cross-cultural environment and are educated in the logistics behind planning a mission trip. This course also examines the accounts of historical missions, especially in the last century, with an emphasis on what God is doing in our world today.

Special Note: Every student is required to participate in one mission trip during the year.

Additional Expectations: Students are expected to raise monetary support to cover the cost of the trip (cost to be determined based on destination). Students must also have a valid passport. Parents must sign the permission document which is standard for all international trips.

ASB BIBLICAL GOVERNMENT

Course Number	0324
Grade Level	11, 12
Pre-Requisite	Application and instructor approval
Application and/or Audition Date	February 9
Grade Scale	Standard
Credits	10
VCHS Graduation Credit	Bible
UC Approval	None
Fees	None

COURSE DESCRIPTION

Exploring biblical leadership through the lens of biblical characters, students study a variety of leaders and the challenges they faced in order to learn what biblical leadership looks like and what that means for how they should lead. Students have the opportunity to gain skills in event planning, ministry planning, public speaking, time management, relationship building, problem solving, and more. This course gives students the knowledge and resources to hold leadership positions in school, church, and community. Significant time outside of course is required for this course.

COMMUNITY OUTREACH

Course Number	0334
Grade Level	11, 12
Pre-Requisite	Application and instructor approval
Application and/or Audition Date	February 9
Grade Scale	Standard
Credits	10
VCHS Graduation Credit	Bible
UC Approval	None
Fees	\$50

COURSE DESCRIPTION

This year-long course trains students to share their personal faith with those around them, compelling unbelievers to encounter the supernatural power of Jesus Christ. Four components are included: a study of biblical prayer and evangelism, research on the effects of prayer on historical Christian revivals and missions, the practice of personal and corporate prayer, and the application of prayer evangelism in cooperation with area churches. This fourth component includes the practical application of the course as students participate in and plan enrichment programs at four local elementary schools with the help of volunteers and Andrew Hill High School.

Additional Expectations: Students should expect at least one hour outside of course per week in planning and preparation for Lighthouse. There is a fee of \$50 for a uniform, which includes a sweatshirt and t-shirt.

ARTS OUTREACH – CONSERVATORY OF THE ARTS

Course Number	0353
Grade Level	11, 12
Pre-Requisite	<i>Conservatory majors and minors only; application and instructor approval</i>
Application and/or Audition Date	February 9
Grade Scale	Standard
Credits	10
VCHS Graduation Credit	Bible
UC Approval	None
Fees	\$50

VALLEY CHRISTIAN SCHOOLS™
 con·ser·va·to·ry
 OF THE ARTS

COURSE DESCRIPTION

This is a year-long course intended to establish a Christian, biblical worldview of the arts. From Genesis to Revelation, God reveals Himself as the master artist who entrusts mankind with the powerful ability to create and communicate through art. The ultimate goal of this course is to equip students to live an influential life that honors the God who gave us our unique abilities, personalities, and talents. Students study art forms as a means of personal and spiritual edification and as a tool for evangelism. Applying the skills they gain, students serve the community through the use of the arts.

Additional Expectations: For one or two days in a two week period, students leave campus during normal course hours to do outreach in local public schools.

CHRISTIAN ATHLETIC LEADERSHIP – HUMAN PERFORMANCE

Course Number	0357
Grade Level	11, 12
Pre-Requisite	<i>Priority for limited space in this course is given to VCHS athletes; application and instructor approval</i>
Application and/or Audition Date	February 9
Grade Scale	Standard
Credits	10
VCHS Graduation Credit	Bible
UC Approval	None
Fees	None



"Do it heartily as to the Lord." Col. 3:23

COURSE DESCRIPTION

This course is designed for students who desire to understand what it truly means to be a Christian athlete and positively impact their teams, our campus, and the community for Christ. Students grapple with a series of questions such as: Does God care about winning and losing? Is there a difference between a Christian athlete and any other athlete? Are sports an appropriate avenue for evangelism? Who are you when age or injury stops you from competing? These, along with other relevant questions, are addressed with the hope that students leave the course with a clearer sense of purpose and identity as a Christian athlete.

Additional Expectations: Community service is an important part of this course. Students may leave course at times during normal course hours to do outreach at a local public school. In addition, occasional evening or weekend hours may be required as a part of the community service component of the course.

ADVANCED COURSES

The following two courses are offered for students who wish to be further involved in leadership or outreach. Courses require successful completion of the corresponding introductory level course, as well as application and instructor approval.

ADVANCED BIBLICAL LEADERSHIP

Course Number	0333
Grade Level	11, 12
Pre-Requisite	Completion of Biblical Leadership; instructor approval
Application and/or Audition Date	February 9
Grade Scale	Standard
Credits	10
VCHS Graduation Credit	Bible
UC Approval	None
Fees	None

COURSE DESCRIPTION

Students are trained to share the knowledge they gained as juniors in Biblical Leadership while serving Valley Christian's student body and the community around them. Students organize and facilitate the Freshman Mentoring ministry as well as train mentors at Valley Christian High School. This course gives students a hands-on opportunity to understand and lead a small group ministry. Students will also complete a capstone project in which they plan and execute an outreach event utilizing the resources from the course.

Additional Expectations: This course requires a minimum of 30 hours per semester of volunteer work outside of course.

Special Note: Admission to this course is highly competitive, and only 5-10 candidates are accepted.

ADVANCED COMMUNITY OUTREACH

Course Number	0307
Grade Level	11, 12
Pre-Requisite	<i>Completion of Community Outreach; application and instructor approval</i>
Application and/or Audition Date	February 9
Grade Scale	Standard
Credits	10
VCHS Graduation Credit	Bible
UC Approval	None
Fees	See "Additional Expectations" note

COURSE DESCRIPTION

This course teaches students to lead their peers in Community Outreach in planning enrichment activities and encouraging students to share their personal faith with those around them, compelling unbelievers to encounter the supernatural power of Jesus Christ. Each student in this course takes the lead in equipping the students in the Community Outreach course. Advanced Community Outreach students head up any advertising for outreach events and fundraisers in which the Community Outreach course participates.

Special Note: Admission to this course is highly competitive, and only 5-10 candidates are accepted.

Additional Expectations: Students should expect a minimum of one hour outside of course per week in planning and preparation for enrichment activities at local elementary schools. There may be a fee for those needing to replace a uniform from the previous year.

DANCE ARTS

DESCRIPTION OF EXCELLENCE

Our mission is to equip students with spiritual, artistic, academic, and technical excellence in dance in order to reclaim the arts as an expression of God's love among the varied cultures of the world. Students learn about the art of dance in a Christian context with strong focus placed on technical and creative excellence as well as an understanding of choreography, exceptional performance styles, physiology, and nutrition.

DISTINCTIVE EXPERIENCE AND ACCOMPLISHMENTS

Students have the opportunity to perform in the Fall Dance Concert, which features choreography from faculty and other dance industry professionals. Students may also participate in *Emotions*, our yearly student choreographed concert, as either a dancer or choreographer. Advanced students may audition for our award-winning competitive dance team, Vivid Dance Company.



Dance courses can be repeated for credit if promotion to next level is not granted by the instructor.

DANCE ARTS COURSES OFFERED

- Dance Technique I
- Dance Technique II
- Dance Technique III
- Dance Technique III Honors
- Tap I
- Tap II
- Tap III
- Hip Hop I
- Hip Hop II
- Hip Hop III

DANCE TECHNIQUE I

Course Number	0528
Grade Level	9, 10, 11, 12
Pre-Requisite	None. No audition necessary
Application and/or Audition Date	None
Grade Scale	Standard
Credits	10
VCHS Graduation Credit	Fine Arts
UC Approval	Yes- Area F (Visual/ Performing Arts)
Fees	\$70

COURSE DESCRIPTION

Dance Technique I introduces dance technique and the fundamentals of movement incorporating the following genres: ballet foundation and jazz technique. As a fundamentals of dance technique course, this course has a strong focus on core strength, alignment, coordination, flexibility, musicality, and overall body awareness for the developing dancer.

Additional Expectations: This course typically requires ½ hour per week of homework. Students in all dance courses have the opportunity to perform in the required dance course showcase *Snapshots* in May. This performance involves three to four evening rehearsals and approximately two 90 minute evening performances. Check with the department for schedule details.

NOTE: DANCE TECHNIQUES 1-3 ARE ALSO OFFERED AS A COLOR GUARD SPECIFIC COURSE. TO ENROLL IN THE COLOR GUARD SPECIFIC DANCE TECHNIQUE I, PLEASE SIGN UP FOR **DANCE TECHNIQUE I – COLOR GUARD (COURSE NUMBER 0528A)**.

DANCE TECHNIQUE II

Course Number	0540
Grade Level	9, 10, 11, 12
Pre-Requisite	<i>Dance Technique I or instructor approval. Mandatory audition</i>
Application and/or Audition Date	March 5, 2018
Grade Scale	3:00-5:00pm
Credits	Standard
VCHS Graduation Credit	10
UC Approval	<i>Fine Arts</i>
Fees	Yes- Area F (Visual/ Performing Arts)
	\$70

COURSE DESCRIPTION

Dance Technique II advances the level of student performance, technique, and understanding of dance. Developing a sampling of lyrical, modern, and jazz, this course includes an intermediate level of dance discipline, academic study, and choreography experiences. As a technique course, this course has a strong focus on core strength, coordination, flexibility, musicality, and overall body awareness for the intermediate dancer.

Additional Expectations: This course typically requires ½ hour per week of homework. Students in all dance courses have the opportunity to perform in the required dance course showcase *Snapshots* in May. This performance involves three to four evening rehearsals and approximately two 90 minute evening performances. Check with the department for schedule details.

NOTE: DANCE TECHNIQUES 1-3 ARE ALSO OFFERED AS A COLOR GUARD SPECIFIC COURSE. TO ENROLL IN THE COLOR GUARD SPECIFIC DANCE TECHNIQUE II, PLEASE SIGN UP FOR **DANCE TECHNIQUE II – COLOR GUARD (COURSE NUMBER 0540A)**.

DANCE TECHNIQUE III

Course Number	0541
Grade Level	9, 10, 11, 12
Pre-Requisite	Audition or instructor approval. Mandatory audition
Application and/or Audition Date	March 5, 2018 3:00-5:00pm
Grade Scale	Standard
Credits	10
VCHS Graduation Credit	Fine Arts
UC Approval	Yes- Area F (Visual/ Performing Arts)
Fees	\$70

COURSE DESCRIPTION

Dance Technique III advances students' understanding of dance history and styles, while increasing their aptitude in technique, performance, and choreography. A sampling of lyrical, modern, contemporary, and jazz is perfected in this course as students' progress toward a collegiate level. Field trips and outside performances are required. As a technique course, this course has a strong focus on core strength, coordination, flexibility, musicality, and overall body awareness for the intermediate/advanced dancer.

Additional Expectations: This course typically requires 60-90 minutes per week of homework. Students in all dance courses have the opportunity to perform in the required dance course showcase *Snapshots* in May. This performance involves three to four evening rehearsals and approximately two 90 minute evening performance. Check with the department for schedule details.

NOTE: DANCE TECHNIQUES 1-3 ARE ALSO OFFERED AS A COLOR GUARD SPECIFIC COURSE. TO ENROLL IN THE COLOR GUARD SPECIFIC DANCE TECHNIQUE III, PLEASE SIGN UP FOR **DANCE TECHNIQUE III – COLOR GUARD (COURSE NUMBER 0541A)**.

COLOR GUARD I

Course Number	0528B
Grade Level	9, 10, 11, 12
Pre-Requisite	None. No audition necessary
Application and/or Audition Date	None
Grade Scale	Standard
Credits	10
VCHS Graduation Credit	Fine Arts
UC Approval	Yes- Area F (Visual/Performing Arts)
Fees	\$70

COURSE DESCRIPTION

Color Guard I introduces dance technique and the fundamentals of movement incorporating the following genres: ballet foundation and jazz technique. As a fundamentals of dance technique course, this course has a strong focus on core strength, alignment, coordination, flexibility, musicality, and overall body awareness for the developing dancer.

Please note that Color Guard I offers the same course content as Dance Technique I, but this course is reserved for students in the Conservatory Color Guard.

Additional Expectations: This course typically requires ½ hour per week of homework. Students in all dance courses have the opportunity to perform in the required dance course showcase *Snapshots* in May. This performance involves three to four evening rehearsals and approximately two 90 minute evening performances. Check with the department for schedule details.

COLOR GUARD II

Course Number	0540B
Grade Level	9, 10, 11, 12
Pre-Requisite	<i>Dance Technique I or instructor approval. Mandatory audition</i>
Application and/or Audition Date	March 5, 2018
Grade Scale	Standard
Credits	10
VCHS Graduation Credit	Fine Arts
UC Approval	Yes- Area F (Visual/ Performing Arts)
Fees	\$70

COURSE DESCRIPTION

Color Guard II advances the level of student performance, technique, and understanding of dance. Developing a sampling of lyrical, modern, and jazz, this course includes an intermediate level of dance discipline, academic study, and choreography experiences. As a technique course, this course has a strong focus on core strength, coordination, flexibility, musicality, and overall body awareness for the intermediate dancer.

Please note that Color Guard II offers the same course content as Dance Technique II, but this course is reserved for students in the Conservatory Color Guard.

Additional Expectations: This course typically requires ½ hour per week of homework. Students in all dance courses have the opportunity to perform in the required dance course showcase *Snapshots* in May. This performance involves three to four evening rehearsals and approximately two 90 minute evening performances. Check with the department for schedule details.

COLOR GUARD III

Course Number	0541B
Grade Level	9, 10, 11, 12
Pre-Requisite	Audition or instructor approval. Mandatory audition
Application and/or Audition Date	March 5, 2018 3:00-5:00pm
Grade Scale	Standard
Credits	10
VCHS Graduation Credit	Fine Arts
UC Approval	Yes- Area F (Visual/ Performing Arts)
Fees	\$70

COURSE DESCRIPTION

Color Guard III advances students' understanding of dance history and styles, while increasing their aptitude in technique, performance, and choreography. A sampling of lyrical, modern, contemporary, and jazz is perfected in this course as students' progress toward a collegiate level. Field trips and outside performances are required. As a technique course, this course has a strong focus on core strength, coordination, flexibility, musicality, and overall body awareness for the intermediate/advanced dancer.

Please note that Color Guard III offers the same course content as Dance Technique III, but this course is reserved for students in the Conservatory Color Guard.

Additional Expectations: This course typically requires 60-90 minutes per week of homework. Students in all dance courses have the opportunity to perform in the required dance course showcase *Snapshots* in May. This performance involves three to four evening rehearsals and approximately two 90 minute evening performance. Check with the department for schedule details.

DANCE TECHNIQUE III HONORS

Course Number	0544
Grade Level	11, 12
Pre-Requisite	Audition or instructor approval. Mandatory audition
Application and/or Audition Date	March 5, 2018
	3:00-5:00pm
Grade Scale	Honors
Credits	10
VCHS Graduation Credit	Fine Arts
UC Approval	Yes- Area F (Visual/Performing Arts)
Fees	\$70

COURSE DESCRIPTION

Dance Technique III Honors expands students' understanding of dance history and styles, while increasing their aptitude in technique, performance, and choreography. A sampling of lyrical, contemporary, modern, and jazz is developed in this course. This is a college level course in technique, academia, and artistry. Students at this level exhibit leadership in the dance department and are expected to choreograph solo and group works for performances, including *Emotions*. Field trips and outside performances are required.

Additional Expectations: This course typically requires 1-2 hours per week of homework. Students choreograph for *Emotions*, which requires at least one hour of rehearsal per week after school and two weeks of after school technical rehearsals in November. Students in all dance courses have the opportunity to perform in the required dance course showcase *Snapshots* in May. This performance involves three to four evening rehearsals and approximately two 90 minute evening performances. Check with the department for schedule details.

TAP I

Course Number	0075
Grade Level	9, 10, 11, 12
Pre-Requisite	None. No audition necessary
Application and/or Audition Date	None
Grade Scale	Standard
Credits	10
VCHS Graduation Credit	Fine Arts
UC Approval	Yes- Area F (Visual/Performing Arts)
Fees	\$70

COURSE DESCRIPTION

Tap I introduces tap dance history, technique, choreography, and principles of academic study. Students develop muscle tone, flexibility, musicality, articulation, phrasing, and alignment for tap dance, improving physical coordination and appreciation for the art form.

Additional Expectations: This course typically requires 1 hour per week of homework. Students in all dance courses have the opportunity to perform in the required dance course showcase *Snapshots* in May. This performance involves three to four evening rehearsals and approximately two 90 minute evening performances. Check with the department for schedule details.

TAP II

Course Number	0098
Grade Level	10, 11, 12
Pre-Requisite	Tap I or instructor approval. Mandatory audition
Application and/or Audition Date	March 5, 2018 3:00-5:00pm
Grade Scale	Standard
Credits	10
VCHS Graduation Credit	Fine Arts
UC Approval	Yes- Area F (Visual/Performing Arts)
Fees	\$70

COURSE DESCRIPTION

Tap II advances the level of student performance, technique, choreography, and understanding of tap dance. This course includes an intermediate level of tap dance discipline, academic study, and choreography experiences with greater focus on rhythm tap, turns, musicality, articulation, and phrasing.

Additional Expectations: This course typically requires 60-90 minutes per week of homework. Students in all dance courses have the opportunity to perform in the required dance course showcase *Snapshots* in May. This performance involves three to four evening rehearsals and approximately two 90 minute evening performances. Check with the department for schedule details.

TAP III

Course Number	0099
Grade Level	10, 11, 12
Pre-Requisite	Audition or instructor approval. Mandatory audition
Application and/or Audition Date	March 5, 2018 3:00-5:00pm
Grade Scale	Standard
Credits	10
VCHS Graduation Credit	Fine Arts
UC Approval	Yes- Area F (Visual/Performing Arts)
Fees	\$70

COURSE DESCRIPTION

Tap III increases the level of student performance, technique, choreography, and understanding of tap dance to that of an advanced level. This course includes advanced technique, academic study, choreography, and improvisation with an emphasis on speed, rhythm tap, musicality, articulation, turns, and phrasing.

Additional Expectations: This course typically requires 60-90 minutes per week of homework. Students in all dance courses have the opportunity to perform in the required dance course showcase *Snapshots* in May. This performance involves three to four evening rehearsals and approximately two 90 minute evening performance. Check with the department for schedule details.

HIP HOP I

Course Number	0546
Grade Level	9, 10, 11, 12
Pre-Requisite	None. No audition necessary
Application and/or Audition Date	None
Grade Scale	Standard
Credits	10
VCHS Graduation Credit	Fine Arts
UC Approval	Yes- Area F (Visual/Performing Arts)
Fees	\$70

COURSE DESCRIPTION

Hip Hop I introduces students to hip hop history, culture, and various dance forms, while increasing their aptitude in technique, performance, and choreography.

Additional Expectations: This course typically requires ½ hour per week of homework. Students in all dance courses have the opportunity to perform in the required dance course showcase *Snapshots* in May. This performance involves two to three evening rehearsals and approximately 90 minute evening performance. Check with the department for schedule details.

HIP HOP II

Course Number	0575
Grade Level	10, 11, 12
Pre-Requisite	<i>Hip Hop I or instructor approval. Mandatory audition</i>
Application and/or Audition Date	March 6, 2018
	3:00-5:00pm
Grade Scale	Standard
Credits	10
VCHS Graduation Credit	Fine Arts
UC Approval	Yes- Area F (Visual/Performing Arts)
Fees	\$70

COURSE DESCRIPTION

Hip Hop II deepens students' understanding of hip hop history, culture, and various dance forms, while increasing their aptitude in technique, performance, and choreography. Students focus is on teacher generated material and refinement of craft

Additional Expectations: This course typically requires 1 hour per week of homework. Students in all dance courses have the opportunity to perform in the required dance course showcase *Snapshots* in May. This performance involves three to four evening rehearsals and approximately two 90 minute evening performances. Check with the department for schedule details.

HIP HOP III

Course Number	0556
Grade Level	10, 11, 12
Pre-Requisite	Audition or instructor approval. Mandatory audition
Application and/or Audition Date	March 6, 2018 3:00-5:00pm
Grade Scale	Standard
Credits	10
VCHS Graduation Credit	Fine Arts
UC Approval	Yes- Area F (Visual/Performing Arts)
Fees	\$70

COURSE DESCRIPTION

This is a repeated course of Hip Hop II. Students who repeat Hip Hop II with a passing grade will have Hip Hop III listed on their transcript for their second year. This course increases the students' abilities in all areas but does not introduce new units. Higher levels of proficiency are expected and encouraged. Student focus is on innovation of movement signature and peer to peer teaching opportunities.

Additional Expectations: This course typically requires 60-90 minutes per week of homework. Students in all dance courses have the opportunity to perform in the required dance course showcase *Snapshots* in May. This performance involves three to four evening rehearsals and approximately two 90 minute evening performances. Check with the department for schedule details.

A young woman with curly hair and glasses is shown in profile, looking down at an open book she is holding. The background is blurred, showing other people in a classroom or library setting. The text is overlaid on a white rectangular area on the right side of the image.

ENGLISH

DESCRIPTION OF EXCELLENCE

The English Department is a perennial winner of Valley Christian School's award for Department of Distinction, distributed to departments who demonstrate and consistently refine best practices in pedagogy and instruction. Teachers of English seek to inspire students to delve enthusiastically into great literature and encourage analysis through the lens of God's truth. Through cultivating critical thinking in students, teachers also train them to express their ideas and beliefs in conversation and writing.

DISTINCTIVE EXPERIENCE AND ACCOMPLISHMENTS

All students are encouraged to enter creative fiction and nonfiction works in local and national competitions. The most recent and notable accomplishments for Valley Christian student writers include national recognition from the Scholastic Arts & Writing awards, the Ayn Rand Institute, and from the Philosophy Learning and Teaching Organization (PLATO). Valley Christian has also had particular success with multiple publications in *Creative Communications*.

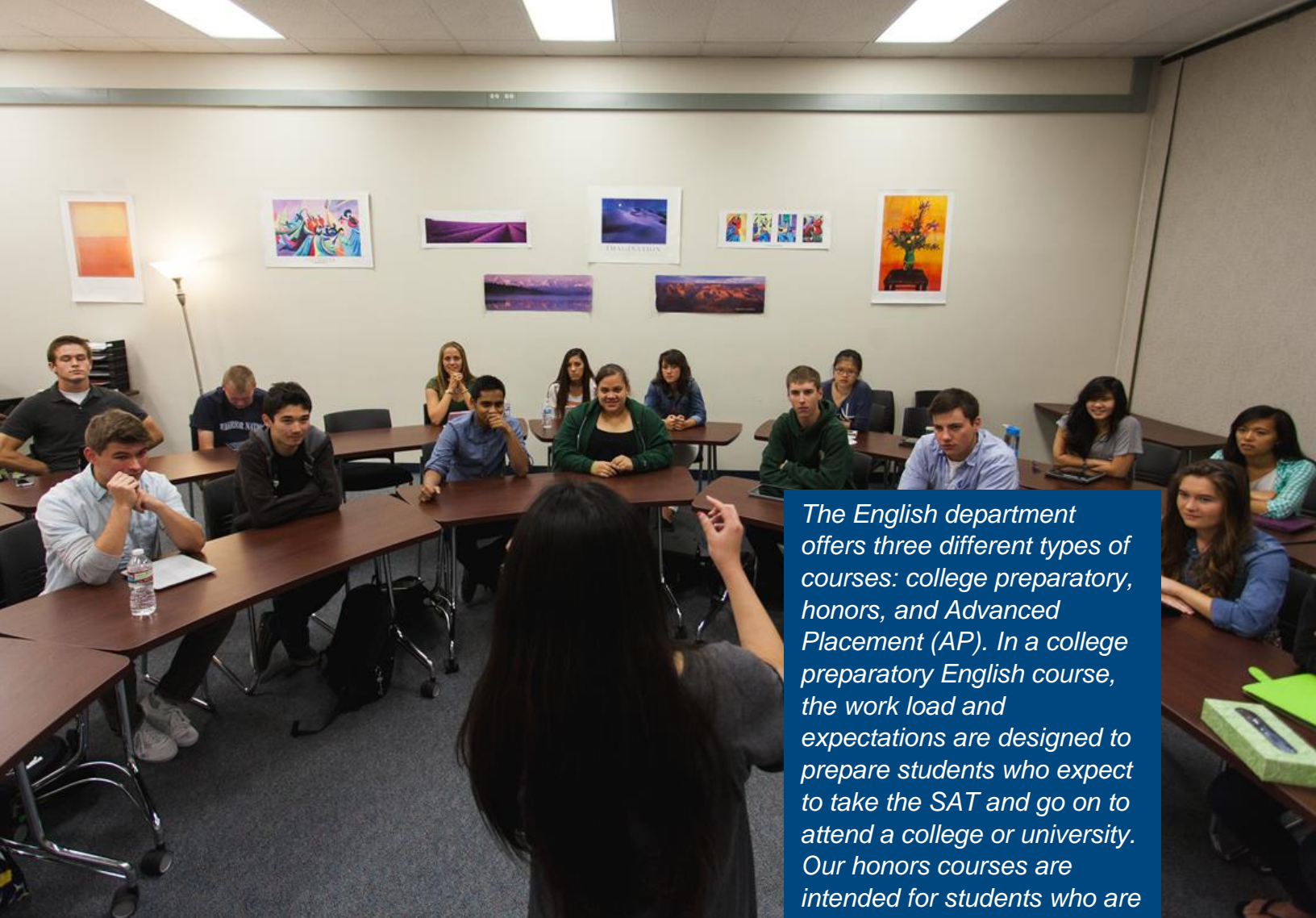

The English department offers three different types of courses: college preparatory, honors, and Advanced Placement (AP). In a college preparatory English course, the work load and expectations are designed to prepare students who expect to take the SAT and go on to attend a college or university. Our honors courses are intended for students who are highly skilled and motivated in English and who possess a strong work ethic. AP courses allow students to take a college-level course in a supportive environment; students should expect corresponding rigor and time required.

Summer reading is required for honors and AP English students at the sophomore, junior, and senior levels.

ENGLISH COURSES OFFERED

- English 9
- English 9 Honors
- English 10
- English 10 Honors
- American Literature
- African American Literature
- Sports in Literature & Writing
- Philosophy in Literature
- AP English Language & Composition
- Early/Late British Literature
- AP English Literature & Composition

ENGLISH 9

Course Number	0100
Grade Level	9
Pre-Requisite	None
Application and/or Audition Date	None
Grade Scale	Standard
Credits	10
VCHS Graduation Credit	English
UC Approval	Yes- Area B (English)
Fees	None

COURSE DESCRIPTION

English 9, a college preparatory course, introduces vital and foundational concepts that will serve students throughout their high school careers. Students study various literary genres: the short story, the play, the epic poem, poetry, and the novel. The course focuses on annotating grade-level texts to strengthen reading comprehension and analysis, which provides the basis for academic writing. Writing centers on paragraph development using specific evidence to support a claim and draw logical conclusions. Using this paragraph structure, students write analysis and argumentative essays. Throughout the year, students deepen and apply their study of grammar and vocabulary.

ENGLISH 9 HONORS*

Course Number	0105
Grade Level	9
Pre-Requisite	<p><i>Grade of A in Grade 8 English or B or higher in Grade 8 Honors English.</i></p> <p><i>It is recommended that incoming VCJH students have a score of 4 or higher on the writing proficiency exam. All other placements will be based on the results of the admissions literary analysis test and essay.</i></p>
Application and/or Audition Date	None
Grade Scale	Honors*
Credits	10
VCHS Graduation Credit	English
UC Approval	Yes- Area B (English)*
Fees	None

COURSE DESCRIPTION

English 9 Honors introduces students to a variety of literary genres, including epic and conventional poetry, the play, the short story, and the novel. This course stresses literary analysis and annotation to more fully engage with literature. Students examine the basics of grammar and the process of writing while improving and expanding their vocabulary. Creative opportunities present themselves throughout the course in forms of self-expression through writing, artwork, and short presentations. In this honors course, individual and group projects, reading comprehension quizzes written assignments, and course discussions require a high level of critical thinking skills.

*Though internal honors credit is given, the UC does not calculate an honors grade point for this course. Other colleges may assign honors credit.

ENGLISH 10

Course Number	0110
Grade Level	10
Pre-Requisite	None
Application and/or Audition Date	None
Grade Scale	Standard
Credits	10
VCHS Graduation Credit	English
UC Approval	Yes- Area B (English)
Fees	None

COURSE DESCRIPTION

English 10, a college preparatory course, builds upon the foundations set in English 9. Students study a variety of literary genres and learn to analyze and respond from a biblical worldview. The course stresses the development and application of literary analysis to improve close reading skills. Students enhance their composition skills with a focus on fine-tuning argumentation and integrating evidence within their persuasive research papers.

ENGLISH 10 HONORS*

Course Number	0115
Grade Level	10
Pre-Requisite	Grade of B or higher in English 9 Honors or grade of A in English 9.
Application and/or Audition Date	None
Grade Scale	Honors*
Credits	10
VCHS Graduation Credit	English
UC Approval	Yes- Area B (English)*
Fees	None

COURSE DESCRIPTION

English 10 Honors is an accelerated, challenging course that builds on the skills learned in English 9 Honors. Throughout the year, students read diverse selections of literature and examine each author's cultural and personal value systems, comparing them to biblical teachings and their own worldview. Students learn the best ways to communicate to the world around them by practicing the craft of writing— specifically, how to engage various audiences, support ideas with evidence, and write effectively in a variety of genres, such as business writing and persuasive essays. This course also stresses the development and application of grammar and vocabulary skills. A summer reading assignment is required.

*Though internal honors credit is given, the UC does not calculate an honors grade point for this course. Other colleges may assign honors credit.

AMERICAN LITERATURE

Course Number	0122
Grade Level	11, 12
Pre-Requisite	None
Application and/or Audition Date	None
Grade Scale	Standard
Credits	10
VCHS Graduation Credit	English
UC Approval	Yes- Area B (English)
Fees	Dual Credit fees

COURSE DESCRIPTION

American Literature, a college preparatory course for 11th grade students, explores the development of American literature from 1607 to the present, examining philosophical trends that shaped the authors and their works. Students study these trends by analyzing essays, personal narratives, short stories, poetry, and novels. The term paper requires independent, compare-and-contrast research on American literary works. Other writing includes argumentative essays and poetry. Special attention is given to advanced grammar and vocabulary enrichment.

Additional Expectations: This is an upper-level high school English course. The work load and expectations are intended to prepare students for the approaching SAT and college application essays.

Note: Juniors may choose between this courses, Sports in Literature, African American Literature, and Philosophy in Literature. The courses are equal in work and requirements.

AFRICAN AMERICAN LITERATURE

Course Number	<i>TBD</i>
Grade Level	<i>11, 12</i>
Pre-Requisite	<i>None</i>
Application and/or Audition Date	<i>None</i>
Grade Scale	<i>Standard</i>
Credits	<i>10</i>
VCHS Graduation Credit	<i>English</i>
UC Approval	<i>Pending</i>
Fees	<i>N/A</i>

COURSE DESCRIPTION

This college preparatory course surveys African American literature from the 18th to 20th centuries from both a historical and literary perspective. We will study a range of genres including novels, short stories, poetry, and autobiographies by African Americans. Texts are explored not only from the perspective of race, but from the larger context of cultural themes, social movements, and literary and artistic connections. Students will develop their writing skills through close reading and response, a series of literary analyses and argumentative essays, and by creating their own original poetry. Special attention will be given to vocabulary enrichment and grammatical application.

Additional Expectations: This is an upper-level high school English course. The work load and expectations are intended to prepare students for the approaching SAT and college application essays.

Note: Juniors may choose between this course, Sports in Literature, American Literature, and Philosophy in Literature. The courses are equal in work and requirements.

SPORTS IN LITERATURE AND WRITING

Course Number	0140
Grade Level	11, 12
Pre-Requisite	English 10
Application and/or Audition Date	None
Grade Scale	Standard
Credits	10
VCHS Graduation Credit	English
UC Approval	Yes- Area B (English)
Fees	None

COURSE DESCRIPTION

Since the late 19th century, sports have become more and more important in American society. Sports have influenced and been influenced by the great themes of the twentieth century, including women's rights, civil liberty, and, often, international affairs. Given this, it is not surprising that many great authors have chosen to express themselves through sports-related subjects.

In this course, students explore topics such as gender, race, heroes and anti-heroes, controversies, and triumphs through the works of Jack London, Gay Talese, David Halberstam, Marianne Moore, Somerset Maugham, and others. Responsive writing in the form of process analysis, personal narrative, expository writing, and argument essays are an integral part of the course.

Note: Juniors may choose between this course, African American Literature, American Literature, and Philosophy in Literature. The courses are equal in work and requirements. It may also be taken by seniors as a fifth year of English.

PHILOSOPHY IN LITERATURE

Course Number	<i>TBD</i>
Grade Level	<i>11, 12</i>
Pre-Requisite	<i>English 10</i>
Application and/or Audition Date	<i>None</i>
Grade Scale	<i>Standard</i>
Credits	<i>10</i>
VCHS Graduation Credit	<i>English</i>
UC Approval	<i>Pending</i>
Fees	<i>None</i>

COURSE DESCRIPTION

Philosophy in Literature addresses major philosophical themes through the study of literature alongside philosophical texts. For instance, what is it to live a good human life? Is beauty out there in the world, like size and shape, or is it merely a product of the mind? How should we form our beliefs and what is it to be a rational person? Would it be morally acceptable to use science to extend human life by, say, 1,000 years? Students will read two major novels: C. S. Lewis' *Till We Have Faces* and Dostoevsky's *Notes From The Underground*. As we read these and other literary works, special attention is paid to the philosophical themes they explore. A major aim of the course is to help students think deeply and carefully about the issues that matter most in life, and to teach students how to generate and assess philosophical reasoning. Students will learn to put these skills to use in their writing, enabling them to produce sharp analytical essays that cut deeply into the issues they address.

Note: Juniors may choose between this course, African American Literature, American Literature, and Sports in Literature and Writing. The courses are equal in work and requirements. It may also be taken by seniors as a fifth year of English.

AP ENGLISH LANGUAGE AND COMPOSITION

Course Number	0153
Grade Level	11, 12
Pre-Requisite	Grade of B or higher in English 10 Honors or grade of A in English 10.
Application and/or Audition Date	None
Grade Scale	Honors
Credits	10
VCHS Graduation Credit	English
UC Approval	Yes- Area B (English)
Fees	AP exam fee

COURSE DESCRIPTION

Words can change and shape the course of history, as students learn in AP English Language and Composition. This intensive course pushes students to extend their critical thinking skills beyond literature to the visual and textual media of today's culture. Analyzing the sometimes subtle differences between logical argument and calculated manipulation, students examine a variety of genres, ranging from political cartoons and modern advertisements to American essays, speeches, and novels. Inspired by the organization, style, and grammatical structure of great communicators as guidance for their own writing, students will mature beyond formulaic writing patterns, developing their own unique and persuasive voice. A summer reading assignment is required.

EARLY/LATE BRITISH LITERATURE PAIRING

The semester-long courses Early British Literature and Late British Literature are paired. Students who enroll in Early British Literature will automatically be enrolled in Late British Literature.

EARLY BRITISH LITERATURE

Course Number	0172
Grade Level	11, 12
Pre-Requisite	None
Application and/or Audition Date	None
Grade Scale	Standard
Credits	5
VCHS Graduation Credit	English
UC Approval	Yes, Semester- Area B (English)
Fees	Dual Credit fees

COURSE DESCRIPTION

Early British Literature surveys selected authors and works beginning in the Anglo-Saxon period and continuing through the Renaissance. Students read a minimum of two major works, including Shakespeare's *Macbeth*. Over the course of the semester, students develop their vocabulary and sharpen their writing skills through a series of literary analyses and timed essays. Special attention is paid to the practical application of grammar to help students revise their writing as they prepare for college.

LATE BRITISH LITERATURE

Course Number	0173
Grade Level	11, 12
Pre-Requisite	None
Application and/or Audition Date	None
Grade Scale	Standard
Credits	5
VCHS Graduation Credit	English
UC Approval	Yes, Semester- Area B (English)
Fees	Dual Credit fees

COURSE DESCRIPTION

Late British Literature surveys selected authors and works beginning in the seventeenth century and continuing through contemporary times. Students read a minimum of two major works, including Ibsen's *Hedda Gabler* and Orwell's *1984*. Over the course of the semester, students develop their vocabulary and sharpen their writing skills through a series of literary analyses and timed essays. Special attention is paid to the practical application of grammar to help students revise their writing as they prepare for college.

AP ENGLISH LITERATURE AND COMPOSITION

Course Number	0166
Grade Level	12
Pre-Requisite	Grade of B or higher in AP English Language or grade of A in other junior English course
Application and/or Audition Date	None
Grade Scale	Honors
Credits	10
VCHS Graduation Credit	English
UC Approval	Yes- Area B (English) Dual Credit fees
Fees	AP exam fee

COURSE DESCRIPTION

AP English Literature and Composition is a challenging course intended for students who love to read, debate, analyze, and write. Sampling literary works from a variety of different genres and eras, the course focuses on answering two questions: “What does the author say?” and “How does he or she say it?” While these questions may seem surprisingly simple, the analysis garnered through course discussions, group work, and activities reveals the subtleties and nuances that make literature richly complex. Students who join AP English Literature should expect rigorous application of critical thinking skills in both their reading and writing assignments.

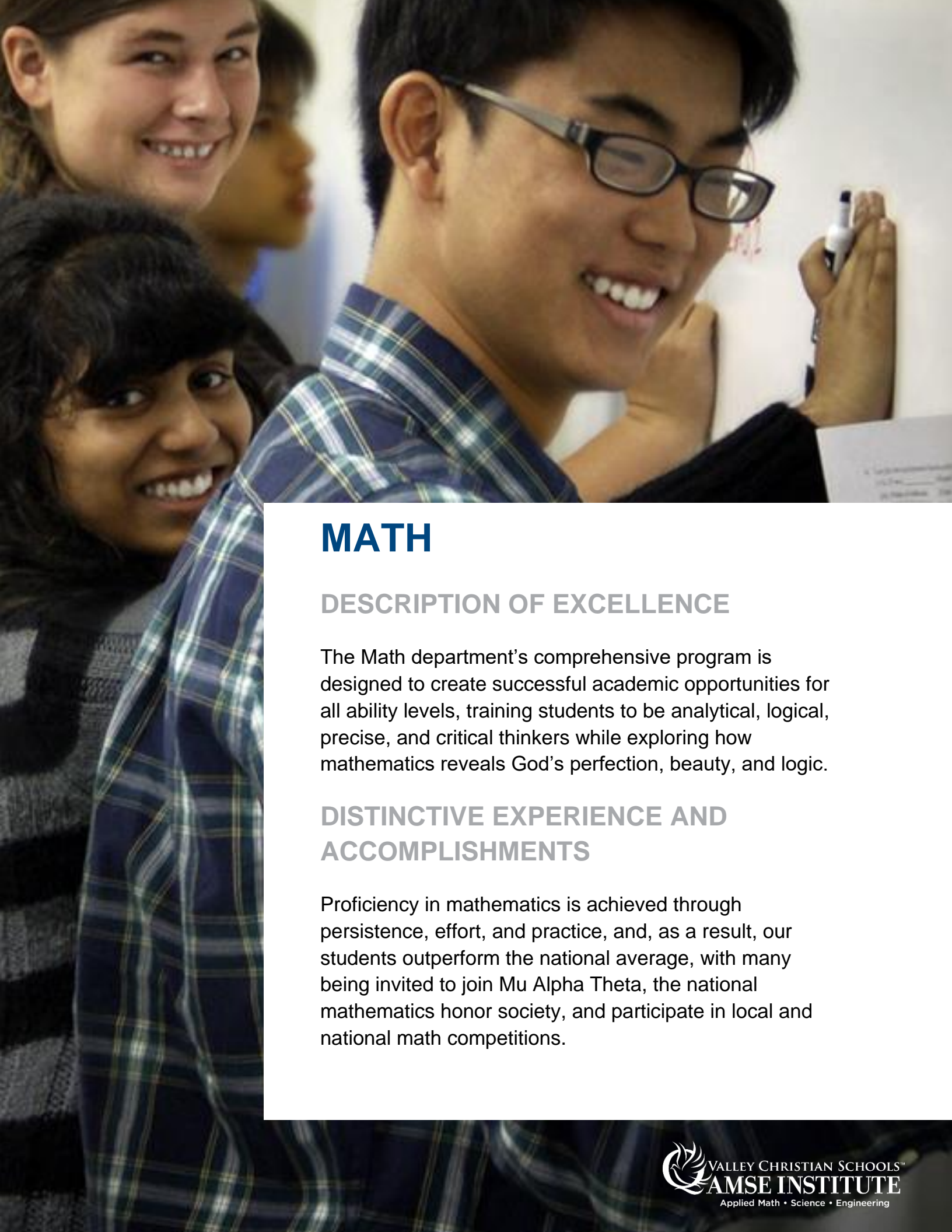

MATH

DESCRIPTION OF EXCELLENCE

The Math department's comprehensive program is designed to create successful academic opportunities for all ability levels, training students to be analytical, logical, precise, and critical thinkers while exploring how mathematics reveals God's perfection, beauty, and logic.

DISTINCTIVE EXPERIENCE AND ACCOMPLISHMENTS

Proficiency in mathematics is achieved through persistence, effort, and practice, and, as a result, our students outperform the national average, with many being invited to join Mu Alpha Theta, the national mathematics honor society, and participate in local and national math competitions.



MATH COURSES OFFERED

- Algebra I (Meets Daily)
- Algebra I
- Geometry (Meets Daily)
- Geometry
- Geometry Honors
- Algebra II (Meets Daily)
- Algebra II
- Algebra II Honors
- Finite Math
- Consumer Math – Online
- Trigonometry/Pre-Calculus
- Trigonometry/Pre-Calculus AB
- Trigonometry/Pre-Calculus BC Honors
- Statistics
- AP Statistics
- Advanced Data Analysis
- Calculus
- AP Calculus AB
- AP Calculus BC
- Multi-Variable Calculus

Many mathematics courses offer an online tutorial. Through an artificial intelligence engine and adaptive questioning, this online tutorial assesses a student's knowledge and delivers individualized instruction on the exact topics a student is most ready to learn. It gives the specific help that each child needs to develop skills and experience the satisfaction of completing a concept.

ALGEBRA I (MEETS DAILY)

Course Number	0831A/0831B
Grade Level	9, 10, 11, 12
Pre-Requisite	Grade of C or higher in Pre-Algebra or equivalent (see VCHS counselor if Pre-Algebra has not been completed for a list of entrance criteria). Entrance examination may be required.
Application and/or Audition Date	None
Grade Scale	Standard
Credits	10
VCHS Graduation Credit	Mathematics
UC Approval	Yes- Area C (Mathematics)
Fees	None

COURSE DESCRIPTION

Daily Algebra I enables students to cover the material in Algebra I in a one year period at a slower pace. The daily structure of this course is designed to help reinforce the concepts taught. Laying a solid foundation of understanding is worth the investment of time in order to ensure success in more advanced mathematics.

Daily Algebra I includes Algebra I curriculum with an extended review of pre-algebra concepts. This daily course counts as one math course, but represents two periods for scheduling purposes.

This course is taught in a flipped instruction style, allowing for minimal homework. Most of the practice problems can be completed in the allotted 85 minute course period, and students are assigned videos to watch at home with minimal practice problems.

This course offers math daily.

ALGEBRA I

Course Number	0810
Grade Level	9, 10
Pre-Requisite	Grade of C or higher in Pre-Algebra or equivalent (see VCHS counselor if Pre-Algebra has not been completed for a list of entrance criteria); entrance examination may be required.
Application and/or Audition Date	None
Grade Scale	Standard
Credits	10
VCHS Graduation Credit	Mathematics
UC Approval	Yes- Area C (Mathematics)
Fees	None

COURSE DESCRIPTION

Algebra I focuses on problem solving by simplifying algebraic expressions and calculating algebraic sentences. Students learn to understand absolute value, apply the properties of arithmetic, and work with inequalities, exponents and polynomials. Students are prepared in the areas of graphs and linear equations, systems of equations, rational expressions, functions, the quadratic equation, and polynomials.

This course is taught in a flipped instruction style. Most of the practice problems can be completed in the allotted 85 minute course period, and students are assigned reading/videos to watch at home with minimal practice problems.

GEOMETRY (MEETS DAILY)

Course Number	0817A/0817B
Grade Level	9, 10, 11, 12
Pre-Requisite	Algebra I; placement examination may be required. Recommendation: Grade of C or higher in both semesters of high school Algebra I or grade of C or higher in 8th grade Algebra I.
Application and/or Audition Date	None
Grade Scale	Standard
Credits	10
VCHS Graduation Credit	Mathematics
UC Approval	Yes- Area C (Mathematics)
Fees	None

COURSE DESCRIPTION

Daily Geometry enables students to cover the material in Geometry in a one year period at a slower pace. The daily structure of this course is designed to help reinforce the concepts taught.

Daily Geometry explores postulates and theorems of plane and solid geometry, parallel and perpendicular lines, polygons, and congruent and similar triangles. The course also covers special right-triangle relationships, trigonometric ratios, circles, area and volume, logic training, conditional statements, and writing various forms of proofs. Curriculum emphasizes algebraic and practical applications of geometry, proofs, and calculations based on geometric properties.

Most of the coursework can be completed in the allotted 85 minute course with minimal homework.

This course offers math daily.

Special Note: A TI-30X or TI-84+ graphing calculator is required.

GEOMETRY

Course Number	0815
Grade Level	9, 10, 11
Pre-Requisite	<i>Algebra I; placement examination may be required. Recommendation: Grade of C or higher in both semesters of high school Algebra I or grade of B or higher in 8th-grade Algebra I.</i>
Application and/or Audition Date	None
Grade Scale	Standard
Credits	10
VCHS Graduation Credit	Mathematics
UC Approval	Yes- Area C (Mathematics)
Fees	None

COURSE DESCRIPTION

Geometry explores postulates and theorems of planar and solid geometry, parallel and perpendicular lines, polygons, and congruent and similar triangles. This course also covers special right-triangle relationships, trigonometric ratios, circles, area and volume, logic training, conditional statements, and writing various forms of proofs. Curriculum emphasizes algebraic and practical applications of geometry, proofs, and calculations based on geometric properties.

This course is a hybrid of both a traditional and flipped instruction format.

Special Note: A TI-30X or TI-84+ graphing calculator is required.

GEOMETRY HONORS*

Course Number	0816
Grade Level	9, 10
Pre-Requisite	Grade of A in Algebra I or teacher recommendation; placement examination will be required.
Application and/or Audition Date	None
Grade Scale	Honors*
Credits	10
VCHS Graduation Credit	Mathematics
UC Approval	Yes- Area C (Mathematics)
Fees	None

COURSE DESCRIPTION

Geometry Honors expands the curriculum of the Geometry course to circles, basic trigonometry, angles of polygons, and transformations with emphasis on algebraic problem solving. Students calculate volumes of prisms, pyramids, cylinders, and cones and learn about symmetry, rotations, and translations. The course also contains additional topics such as vectors, Law of Sines, and Law of Cosines suitable for Honors class.

Special Note: A TI-30X or a TI-84+ graphing calculator is required.

*Though internal honors credit is given, the UC does not calculate an honors grade point for this course. Other colleges may assign honors credit.

ALGEBRA II (MEETS DAILY)

Course Number	0826A/0826B
Grade Level	10, 11, 12
Pre-Requisite	Algebra I and Geometry; placement examination may be required. Recommendation: Grade of C or higher in Algebra I and Geometry.
Application and/or Audition Date	None
Grade Scale	Standard
Credit	10
VCHS Graduation Credit	Mathematics
UC Approval	Yes- Area C (Mathematics)
Fees	None

COURSE DESCRIPTION

This course is designed for students who would benefit from a slower paced introduction to algebraic concepts. It covers most elements in the regular Algebra II course, but students meet daily with the teacher, rather than every other day.

Daily Algebra II presents function notation, linear equations, factoring, quadratic and polynomial equations, and radical expressions. Students work with complex numbers, exponential and rational functions, logarithms, and simple statistics. Curriculum includes an introduction to conic sections, sequences and series, and a brief introduction to trigonometry. This course includes an extended review and reinforcement of algebra concepts. This daily course counts as one math course, but represents two periods for scheduling purposes.

Homework is minimal, as much of the coursework can be completed in the allotted 85 minute course period.

Special Note: A TI-84+ graphing calculator is required.

This course offers math daily.

ALGEBRA II

Course Number	0820
Grade Level	10, 11
Pre-Requisite	<i>Algebra I and Geometry with a grade of C or higher. Placement examination may be required. This course is not open to freshmen without counselor approval.</i>
Application and/or Audition Date	None
Grade Scale	Standard
Credit	10
VCHS Graduation Credit	Mathematics
UC Approval	Yes- Area C (Mathematics)
Fees	None

COURSE DESCRIPTION

Algebra II presents function notation, linear equations, factoring, quadratic and polynomial equations, and radical expressions. Students work with complex numbers, exponential and rational functions, logarithms, and simple statistics. Curriculum includes an introduction to conic sections, sequences and series, and an introduction to trigonometry. This course includes a review and reinforcement of Algebra I concepts.

Special Note: A TI-84+ graphing calculator is required.

ALGEBRA II HONORS*

Course Number	0821
Grade Level	9, 10, 11
Pre-Requisite	<p><i>Algebra I and Geometry; placement examination will be required.</i></p> <p><i>Recommended: Grade of A in Algebra I and grade of B or higher in Geometry Honors, or teacher recommendation only in Geometry.</i></p>
Application and/or Audition Date	None
Grade Scale	Honors*
Credit	10
VCHS Graduation Credit	Mathematics
UC Approval	Yes- Area C (Mathematics)
Fees	None

COURSE DESCRIPTION

Algebra II Honors expands and accelerates all topics found in Algebra II, including probability, an introduction to statistics, linear, quadratic and polynomial functions, rational equations, complex numbers, factoring polynomials, radical expressions, exponential functions, logarithms, conic sections, sequence and series, and trigonometry.

Special Note: A TI-84+ graphing calculator is required.

*Though internal honors credit is given, the UC does not calculate an honors grade point for this course. Other colleges may assign honors credit.

FINITE MATH

Course Number	0849
Grade Level	10, 11, 12
Pre-Requisite	Algebra II with a Grade of C- or higher
Application and/or Audition Date	None
Grade Scale	Standard
Units	10
VCHS Graduation Credit	Mathematics
UC Approval	Yes- Area C (Mathematics)
Fees	None

COURSE DESCRIPTION

Finite Math is designed for students who are seeking an applied math course that emphasizes application to business, economics, social, and behavioral sciences. This course is ideal for students who have completed Algebra II, and will be majoring in Business.

Finite Math includes linear functions, systems of linear equations, matrices, linear programming with both geometric and algebraic approaches, sets and counting, probability distributions, statistics, and finance. The finance portion uses time-value-of-money functions to analyze financial instruments such as annuities, loans, mortgages, leases, and savings.

This is an excellent course for students wishing to prepare themselves for the college entry level mathematics exam or for students who intend to major in Business. It is similar to Finite Math courses offered to business majors at the college level.

Special Note: A TI-84+ graphing calculator is required.

CONSUMER MATH - ONLINE

Course Number	0802X
Grade Level	10, 11, 12
Pre-Requisite	Geometry
Application and/or Audition Date	None
Grade Scale	Standard
Credit	10
VCHS Graduation Credit	Mathematics
UC Approval	None
Fees	\$75

COURSE DESCRIPTION

*The Consumer Math course is intended for students who need to fulfill the three year math requirement for graduation but who do not wish to move on to Algebra II. **Students who take this course instead of Algebra II will not meet the eligibility requirements for 4-year colleges and universities.***

This online BYU course reviews basic math operations, transferring concepts and skills gained in course to everyday situations. Topics include budgeting, insurance, banking, mortgages, and measurement.

THIS COURSE OFFERS A FACILITATOR WHO CHECKS STUDENT PROGRESS AND UPDATES GRADES BIWEEKLY.

TRIGONOMETRY/PRE-CALCULUS

Course Number	0825B
Grade Level	10, 11, 12
Pre-Requisite	Grade of B or higher in Algebra II and Geometry. Placement examination may be required.
Application and/or Audition Date	None
Grade Scale	Standard
Credit	10
VCHS Graduation Credit	Mathematics
UC Approval	Yes- Area C (Mathematics)
Fees	None

COURSE DESCRIPTION

Trig/Pre-Calculus is designed to challenge students who have completed Algebra II This course helps students gain comprehension of and proficiency in high-level foundational concepts. Students can move on to Finite Math, Calculus, or Statistics after this course.

This one-year course covers the basics of trigonometry and pre-calculus using the techniques that students have previously learned from their study of algebra and geometry; the trigonometric functions studied are defined geometrically and in terms of algebraic equations. Students develop skills with these functions as well as the ability to prove basic identities regarding them. This course also prepares students for the study of calculus and strengthens their conceptual understanding of problems and mathematical reasoning in solving problems. This is especially important for students intending to study calculus, statistics, or business math in college.

Special Note: A TI-84+ graphing calculator is required.

TRIGONOMETRY/PRE-CALCULUS AB

Course Number	0825A
Grade Level	10, 11, 12
Pre-Requisite	Grade C or higher in Algebra II Honors. Teacher recommendation must be provided to a counselor for students coming from Algebra II & Algebra II Daily. Placement examination may be required.
Application and/or Audition Date	None
Grade Scale	Standard
Credit	10
VCHS Graduation Credit	Mathematics
UC Approval	Yes- Area C (Mathematics)
Fees	Dual Credit fees

COURSE DESCRIPTION

This course focuses on preparing students to be successful in AP Calculus AB and college level calculus courses. Designed for students with high mathematic ability, Trig/Pre-Calculus AB is foundational for advanced high school physics courses.

This course prepares students to be successful in AP Calculus AB. The course covers all major topics in trigonometry, including basic properties of trigonometric functions, inverse trigonometric functions, radians, Law of Sines and Cosines, double and half-angle formulas, identities, polar coordinates, and polar equations. The pre-calculus portion reviews and extends concepts taught in Algebra II and then advances to vectors, parametric and polar equations, sequences, and series, and ends with an introduction to calculus.

Special Note: A TI-84+ graphing calculator is required.

TRIGONOMETRY/PRE-CALCULUS BC HONORS

Course Number	0833
Grade Level	9, 10, 11, 12
Pre-Requisite	Grade B- or higher in Algebra II Honors. Placement examination will be required.
Application and/or Audition Date	None
Grade Scale	Honors
Credit	10
VCHS Graduation Credit	Mathematics
UC Approval	Yes- Area C (Mathematics)
Fees	Dual Credit fees

COURSE DESCRIPTION

This course focuses on preparing students to be successful in AP Calculus BC courses and college level Calculus courses, is foundational for advanced high school physics courses and is for students with high mathematic ability.

This is a Pre-Calculus BC course which prepares students to be successful in AP Calculus BC. This course covers all major topics in trigonometry, including standard properties of trigonometric functions, inverse trigonometric functions, radians, Law of Sines and Cosines, double and half-angle formulas, identities, complex numbers, matrices, determinants, polar coordinates, and polar equations. The Pre-Calculus portion explores three methods of solving systems of equations: algebraic, analytic, and with graphing calculators. Pre-Calculus topics include vectors in two and three dimensions, parametric equations, conic sections in parametric and polar form, sequences, series, and math induction. This course includes a formal introduction to calculus, limits and continuity, derivatives and Calculus A topics to prepare for AP Calculus BC.

Special Note: TI-84+ graphing calculator is required.

STATISTICS

Course Number	0850
Grade Level	10, 11, 12
Pre-Requisite	Algebra II with a grade of C- or higher.
Application and/or Audition Date	None
Grade Scale	Standard
Credit	10
VCHS Graduation Credit	Mathematics
UC Approval	Yes- Area C (Mathematics)
Fees	None

COURSE DESCRIPTION

Statistics is designed for students who are seeking a math course that emphasizes application to business, economics, and social and behavioral sciences. It will help prepare students for advanced math, AP Statistics, or university-level statistics or analytics.

Statistics focuses on the use of real data and the importance of relevance, context, and the interpretation of results. Topics include the role of statistics, the data analysis process, graphical methods for displaying data, numerical methods for describing data, linear regression and correlation. In addition, nonlinear relations, transformations, random variables, probability distributions, sampling variability, sampling distributions, and confidence intervals are studied. The course covers both analytical and inferential statistics. JMP software is introduced and used as a teaching tool in the classroom. This course is designed for students who desire to take an advanced math course but do not wish to take an AP course.

Special Note: A TI-84+ graphing calculator is required.

AP STATISTICS

Course Number	0844
Grade Level	10, 11, 12
Pre-Requisite	Algebra II, Statistics, or Trigonometry/ Pre-Calculus. Recommendation: Grade of B or higher in Algebra II or grade of C or higher in Statistics or Trigonometry/ Pre-Calculus.
Application and/or Audition Date	None
Grade Scale	Honors
Credit	10
VCHS Graduation Credit	Mathematics
UC Approval	Yes- Area C (Mathematics)
Fees	Dual Credit fees

COURSE DESCRIPTION

This course is designed for students who have successfully completed Algebra II and possess sufficient mathematical maturity and quantitative reasoning ability.

This course covers major introductory topics in both descriptive and inferential statistics, such as mean, median, mode, variance, standard deviation, linear and nonlinear regression, correlation, and hypothesis testing. Students learn sampling procedures, estimate population characteristics, find and interpret confidence intervals, test hypotheses, compare two populations, and develop chi-squared tests. Students also learn to apply techniques for normal, binomial, geometric, and other discrete and continuous probability distributions. Students will learn to use JMP statistical analysis software on computers and iPads. Microsoft Excel is used as a teaching tool in the classroom and is used by students on their computers and iPads. This course includes preparation and review for the AP statistics examination.

Special Note: TI-84+ graphing calculator is required.

ADVANCED DATA ANALYSIS*

Course Number	0889
Grade Level	11, 12
Pre-Requisite	AP Statistics. Grade of C or higher in AP Statistics.
Application and/or Audition Date	None
Grade Scale	Honors
Credit	10
VCHS Graduation Credit	Mathematics
UC Approval	Yes
Fees	None

COURSE DESCRIPTION

This course is designed for students who have successfully completed AP Statistics.

This is a second level course in statistical analysis of data for scientific and medical research, business, engineering, and economics. Students further their studies in techniques of data collection, real data analysis, applications using exponential, Gamma, Weibull, lognormal and Poisson distributions, writing hypotheses and conclusions, multiple regression, nonlinear regression, transformations to normalize data, one-way and two-way analysis of variance (ANOVA), Chi-Squared tests, nonparametric statistics, econometrics, modern product improvement techniques, and acceptance sampling. Students see many applications of the techniques used in real life data sets, work on projects interpretation of computer output, and instruction in using JMP software to empower scientists and engineers to explore data visually. Students will learn how to use statistics to analyze and draw conclusions from research data.

Special Note: TI-84+ graphing calculator is required.

*Though internal honors credit is given, the UC does not calculate an honors grade point for this course. Other colleges may assign honors credit.

CALCULUS

Course Number	0804
Grade Level	11, 12
Pre-Requisite	Trigonometry/ Pre-Calculus. Recommendation: Grade of C or higher in Trigonometry. Placement examination may be required.
Application and/or Audition Date	None
Grade Scale	Standard
Credit	10
VCHS Graduation Credit	Mathematics
UC Approval	Yes- Area C (Mathematics)
Fees	Dual Credit fees

COURSE DESCRIPTION

Course content includes limits and continuity, derivatives (slopes of functions at a point), min-max problems, related rates, rectilinear motion, integrals, Riemann sums, and the calculus of transcendental functions. Students in this course will get an excellent foundation for the high level Calculus courses in college. Students may move to Statistics after Calculus.

Special Note: TI-84+ graphing calculator is required.

AP CALCULUS AB

Course Number	0835
Grade Level	11, 12
Pre-Requisite	<p><i>Trigonometry/Pre-Calculus AB.</i></p> <p><i>Recommendation: Grade of B or higher in Trigonometry/Pre AP Calculus AB or grade of C or higher in Trigonometry/Pre-Calculus BC Honors. Placement examination may be required.</i></p>
Application and/or Audition Date	None
Grade Scale	Honors
Credits	10
VCHS Graduation Credit	Mathematics
UC Approval	Yes- Area C (Mathematics)
Fees	Dual Credit fees

COURSE DESCRIPTION

The AP Calculus AB course consists of a full high school academic year of work that is comparable to the first semester of college calculus. This course makes extensive use of pre-requisite math skills, including algebra, geometry, trigonometry, and pre-calculus. Course content includes limits and continuity, derivatives, min-max problems, related rates, rectilinear motion, integrals, Riemann sums, differential equations, volumes of rotation, and the calculus of transcendental functions. This course includes a rigorous review for the AP Calculus AB examination.

Special Note: TI-84+ graphing calculator is required.

AP CALCULUS BC

Course Number	0840
Grade Level	10, 11, 12
Pre-Requisite	<p><i>Trigonometry/Pre-Calculus BC Honors or AP Calculus AB; placement examination may be required.</i></p> <p><i>Recommendation: Grade of B or higher in Trigonometry/Pre-Calculus BC Honors or grade of B or higher in AP Calculus AB.</i></p>
Application and/or Audition Date	None
Grade Scale	Honors
Credits	10
VCHS Graduation Credit	Mathematics
UC Approval	Yes- Area C (Mathematics)
Fees	None

COURSE DESCRIPTION

The AP Calculus BC course consists of a full year course in the calculus of functions of a single variable. Students who take this course should do so with the intention of placing out of a comparable college calculus course. The course makes extensive use of pre-requisite math skills, including algebra, geometry, trigonometry, and pre-calculus. The course covers all topics required in AP Calculus AB, with additional (Calculus C) topics, including integration by parts, integration by partial fractions, MacLaurin and Taylor series, and calculus applied to parametric and polar equations. This course begins by reviewing pre-calculus (Calculus A) topics at a quick pace, assuming coverage in a previous math course. The AP Calculus BC course is designed to cover two semesters of college calculus. This course includes a rigorous review for the AP Calculus BC examination.

Special Note: TI-84+ graphing calculator is required.

MULTIVARIABLE CALCULUS*

Course Number	0838
Grade Level	11, 12
Pre-Requisite	<i>Pre-Requisite: AP Calculus BC. Recommendation: Grade of B or higher in AP Calculus BC and passage of both the AB and BC sub-scores of the AP Calculus BC exam with minimum scores of 4 or 5. Multi-Variable Calculus is a second year university level course.</i>
Application and/or Audition Date	None
Grade Scale	Honors*
Credits	10
VCHS Graduation Credit	Mathematics
UC Approval	Yes- Area C (Mathematics)
Fees	Dual Credit fees

COURSE DESCRIPTION

Students begin by reviewing topics from AP Calculus BC, covering differential and integral calculus of a single variable. Students receive more in-depth instruction on advanced related rates, solids of revolution (including shell method), and advanced integration techniques. The principal topics of this course are the differential and integral calculus of several variables and their application to scalar and vector fields. Course content includes calculus of vector valued functions, partial derivatives, min-max problems of functions of several variables, and double and triple integrals.

Special Note: TI-84+ graphing calculator is required.

*Though internal honors credit is given, the UC does not calculate an honors grade point for this course. Other colleges may assign honors credit.

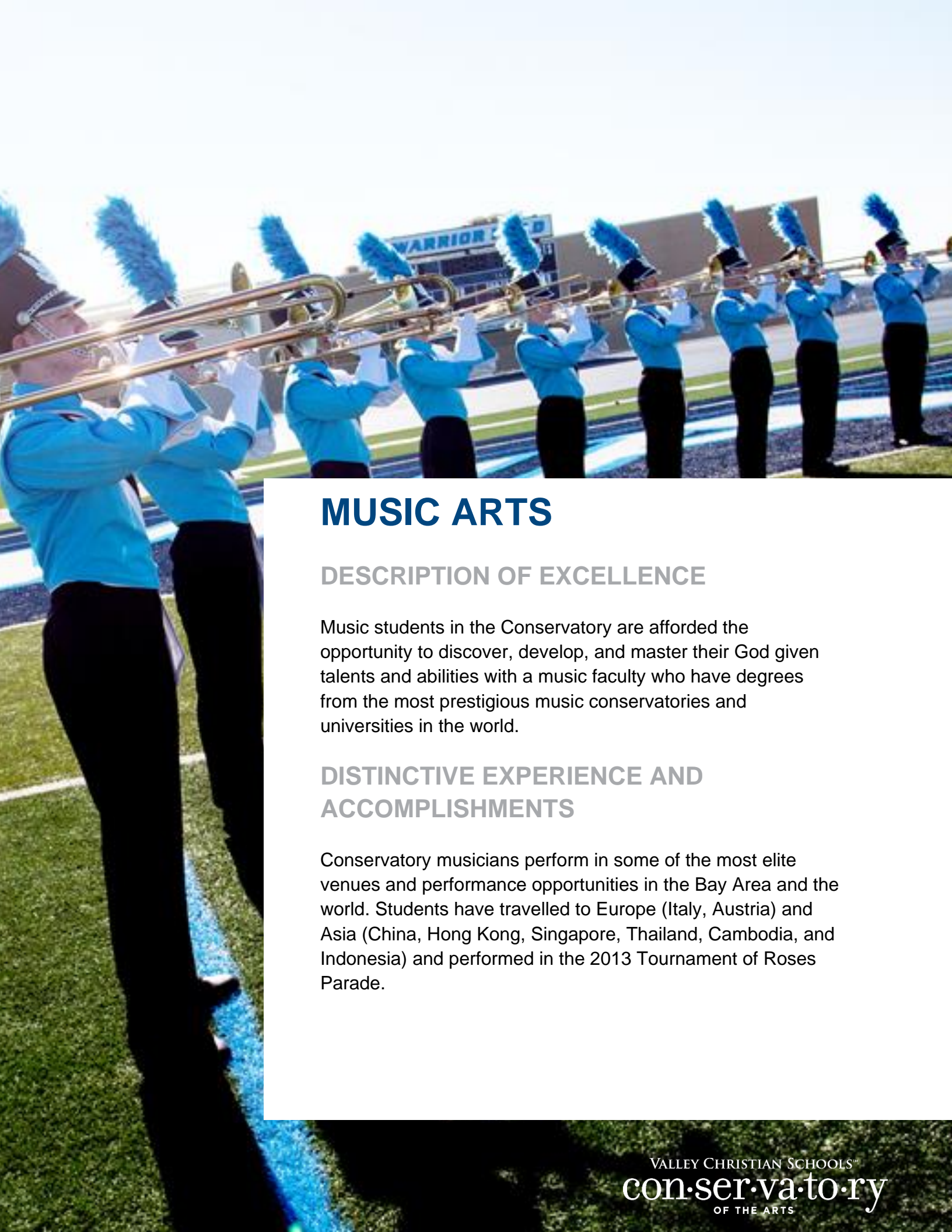

MUSIC ARTS

DESCRIPTION OF EXCELLENCE

Music students in the Conservatory are afforded the opportunity to discover, develop, and master their God given talents and abilities with a music faculty who have degrees from the most prestigious music conservatories and universities in the world.

DISTINCTIVE EXPERIENCE AND ACCOMPLISHMENTS

Conservatory musicians perform in some of the most elite venues and performance opportunities in the Bay Area and the world. Students have travelled to Europe (Italy, Austria) and Asia (China, Hong Kong, Singapore, Thailand, Cambodia, and Indonesia) and performed in the 2013 Tournament of Roses Parade.



MUSIC ARTS COURSES OFFERED

- Symphonic Band
- Wind Ensemble
- Jazz Lab
- Jazz Ensemble Honors
- String Ensemble
- Chamber Ensemble
- Percussion Ensemble
- Piano I
- Piano II
- Piano III
- Introduction to Guitar and Electric Bass
- Guitar II
- Guitar III
- Conservatory Chorus
- Worship Choir
- Vocal Jazz Ensemble
- AP Music Theory
- Music Technology
- History and Music (listed in Social Science Section of Course Catalog)

SYMPHONIC BAND

Course Number	0090
Grade Level	9, 10, 11, 12
Pre-Requisite	<i>Experience playing a wind instrument; Teacher Approval</i>
Application and/or Audition Date	None
Grade Scale	Standard
Credits	10
VCHS Graduation Credit	Fine Arts
UC Approval	Yes- Area F (Visual/ Performing Arts)
Fees	\$200-\$2,500 <i>dependent upon trips planned for the year.</i>

COURSE DESCRIPTION

This course develops musicianship and technical skills through performing intermediate and advanced-level literature from both the classical and popular musical genres. In addition to refining rehearsal and performance techniques, students study music theory and history. Additional rehearsals and performances are scheduled at the discretion of the director. This course may be repeated for additional credit.

Additional Expectations: Participation in approximately 5 performances throughout the year.

Special Note: This ensemble meets the "instrument specific core performance requirement" for all brass and woodwind majors and minors.

WIND ENSEMBLE

Course Number	0072
Grade Level	9, 10, 11, 12
Pre-Requisite	Audition required; instructor approval
Application and/or Audition Date	Auditions held in Spring 2018;
Grade Scale	Standard
Credits	10
VCHS Graduation Credit	Fine Arts
UC Approval	Yes- Area F (Visual/ Performing Arts)
Fees	\$200-\$2,500, dependent upon trips planned for the year.

COURSE DESCRIPTION

This course serves as the premier performance course for advanced level wind instrumentalists, developing musicianship and technical skills through performing literature from both the classical and contemporary musical genres. In addition to mastering rehearsal and performance techniques, students study music theory and history. Additional rehearsals and performances are scheduled at the discretion of the director. This course may be repeated for additional credit.

Additional Expectations: Enrollment in private lessons. Participation in approximately 10 performances throughout the year.

Special Note: This ensemble meets the "instrument specific core performance requirement" for all brass and woodwind majors and minors.

JAZZ LAB

Course Number	0023
Grade Level	9, 10, 11, 12
Pre-Requisite	<i>Audition required; instructor approval; Concurrent enrollment in instrument specific core performance ensemble</i>
Application and/or Audition Date	<i>Auditions held in Spring 2018</i>
Grade Scale	<i>Standard</i>
Credits	10
VCHS Graduation Credit	<i>Fine Arts</i>
UC Approval	<i>Yes- Area F (Visual/ Performing Arts)</i>
Fees	<i>\$200-\$2,500, dependent upon trips planned for the year.</i>

COURSE DESCRIPTION

This course is designed for traditional jazz instrumentation of trumpet, trombone, saxophone, and rhythm section (Drum set, hand percussion, bass guitar, guitar, piano/keyboards) and focuses on beginning jazz theory, history, and improvisation. In addition to learning rehearsal and improvisational techniques, students are exposed to various jazz styles and the art of improvisation through extensive listening to historical performances.

Performances may be required at the discretion of the director. This course may be repeated for additional credit.

Additional Expectations: Participation in approximately 10 performances throughout the year. Private lessons are strongly encouraged.

JAZZ ENSEMBLE HONORS

Course Number	0067
Grade Level	9, 10, 11, 12
Pre-Requisite	<i>Audition required; instructor approval; concurrent enrollment in instrument specific core performance ensemble</i>
Application and/or Audition Date	<i>Auditions in Spring 2018</i>
Grade Scale	<i>Honors</i>
Credits	10
VCHS Graduation Credit	<i>Fine Arts</i>
UC Approval	<i>Yes- Area F (Visual/ Performing Arts)</i>
Fees	<i>\$200-\$2,500, dependent upon trips planned for the year.</i>

COURSE DESCRIPTION

This course further develops jazz skills through performing intermediate and advanced-level literature. The curriculum is divided into the following categories: composition, jazz history, improvisational theory, and jazz styles/specific instrumental skills. Students achieve performance skills incorporating the historically oral and aural tradition of jazz music. Additional rehearsals and performances are scheduled at the discretion of the director. This course may be repeated for additional credit.

Additional Expectations: Participation in approximately 10 performances throughout the year. Private lessons are strongly encouraged.

STRING ENSEMBLE

Course Number	0071
Grade Level	9, 10, 11, 12
Pre-Requisite	<i>Instructor approval; Experience playing a string instrument</i>
Application and/or Audition Date	<i>Consult instructor</i>
Grade Scale	<i>Standard</i>
Credits	10
VCHS Graduation Credit	<i>Fine Arts</i>
UC Approval	<i>Yes- Area F (Visual/ Performing Arts)</i>
Fees	<i>\$200-\$2,500, dependent upon trips planned for the year.</i>

COURSE DESCRIPTION

This course builds and develops experience with orchestral performance through intermediate and advanced-level music from the baroque, classical, romantic, and contemporary music periods. Curriculum includes music theory and history in addition to technique. Additional rehearsals and performances are scheduled at the discretion of the director. This course may be repeated for additional credit.

Additional Expectations: Participation in approximately 10 performances throughout the year. Private lessons are strongly encouraged.

Special Note: This ensemble meets the "instrument specific core performance requirement" for all string majors and minors.

CHAMBER ENSEMBLE

Course Number	0035
Grade Level	9, 10, 11, 12
Pre-Requisite	<i>Audition required; Instructor approval; Concurrent enrollment in String Ensemble</i>
Application and/or Audition Date	<i>Auditions held in Spring 2018</i>
Grade Scale	<i>Standard</i>
Credits	10
VCHS Graduation Credit	<i>Fine Arts</i>
UC Approval	<i>Yes- Area F (Visual/ Performing Arts)</i>
Fees	<i>\$200-\$2,500, dependent upon trips planned for the year.</i>

COURSE DESCRIPTION

This is a performance-based course where students have the opportunity to play instruments similar to the historical instruments of the Baroque era. The course includes Baroque and Renaissance performance practice of the string and recorder families. Students have opportunities to perform pieces from the vast literature of the era. The knowledge, skills, and technique learned have a beneficial effect on students' modern counterpart instrumental studies. This course integrates study of individual composers, their faith and devotion, and the sacred music they wrote within the context of the leading role the church played in the arts. This course may be repeated for additional credit.

Additional Expectations: Enrollment in private lessons. Participation in approximately 10 performances throughout the year.

PERCUSSION ENSEMBLE

Course Number	1027
Grade Level	9, 10, 11, 12
Pre-Requisite	Instructor approval;
Application and/or Audition Date	None
Grade Scale	Standard
Credits	10
VCHS Graduation Credit	Fine Arts
UC Approval	Yes- Area F (Visual/ Performing Arts)
Fees	\$200-\$2,500, dependent upon trips planned for the year.

COURSE DESCRIPTION

This course focuses on rudimentary percussion technique on all the major orchestral percussive instruments. Curriculum includes training for and performing with the Conservatory Wind Ensemble, Symphonic Band, and Symphonic. Students may opt to participate in the Open Air Ensemble (OAE) and Performing Indoor Ensemble (PIE). Curriculum and performances with the OAE are in addition to the orchestral percussion training and performances. In addition to mastering rehearsal and performance techniques, students learn music theory and history. Additional rehearsals and performances are scheduled at the discretion of the director. This course may be repeated for additional credit.

Additional Expectations: Participation in approximately five performances/festivals is required.

Special Note: This ensemble meets the "instrument specific core performance requirement" for all percussionmajors and minors.

PIANO I

Course Number	0064
Grade Level	9, 10, 11, 12
Pre-Requisite	<i>Course enrollment is limited, and priority will be based on seniority and previous Conservatory involvement.</i>
Application and/or Audition Date	None
Grade Scale	Standard
Credits	10
VCHS Graduation Credit	Fine Arts
UC Approval	Yes- Area F (Visual/ Performing Arts)
Fees	None

COURSE DESCRIPTION

This course exposes students to the technical, innovative, and expressive aspects of the piano. While studying western tonality, music theory, and great pianists of the 20th century, students learn the fundamental concepts of playing the piano. The course emphasizes intervallic reading and also develops the ear with the inclusion of aural training. Students acquire the language of music, including intervals, chords, scales, articulation, meter, and harmonization. Repertoire ranges from classical to contemporary. This course may be repeated for additional credit.

Special Note: This ensemble meets the "instrument specific core performance requirement" for all piano majors and minors.

PIANO II

Course Number	0065
Grade Level	9, 10, 11, 12
Pre-Requisite	<i>Piano I or instructor approval</i>
Application and/or Audition Date	None
Grade Scale	Standard
Credits	10
VCHS Graduation Credit	Fine Arts
UC Approval	Yes- Area F (Visual/Performing Arts)
Fees	None

COURSE DESCRIPTION

This course builds on Piano I and continues to give students an opportunity to study the technical, creative and expressive aspects of the piano. In addition to studying western tonality, music theory, and some of the great composers of the past, students further develop their pianistic skills and appreciation for the role the piano has played in society.

Special Note: This ensemble meets the "instrument specific core performance requirement" for all piano majors and minors.

PIANO III

Course Number	0077
Grade Level	9, 10, 11, 12
Pre-Requisite	<i>Conservatory enrollment; Piano II or instructor approval.</i>
Application and/or Audition Date	None
Grade Scale	Standard
Credits	10
VCHS Graduation Credit	Fine Arts
UC Approval	Yes- Area F (Visual/Performing Arts)
Fees	None

COURSE DESCRIPTION

This advanced level course for pianists offers students the opportunity to master the technical, creative, and expressive aspects of the piano. While learning western tonality, historical periods of music, music theory, ensemble playing, and solo repertoire, students also study great pianistic composers of the past and present. Students study composition and performance practices of the masters, including Bach, Mozart, Chopin, Rachmaninoff, and Liszt. This course also reinforces the techniques and skills introduced to conservatory students through private study. Reading, listening assignments, analysis, and performance projects are incorporated into the curriculum.

Special Note: This ensemble meets the "instrument specific core performance requirement" for all piano majors and minors.

INTRODUCTION TO GUITAR AND ELECTRIC BASS

Course Number	0036
Grade Level	9, 10, 11, 12
Pre-Requisite	None
Application and/or Audition Date	None
Grade Scale	Standard
Credits	10
VCHS Graduation Credit	Fine Arts
UC Approval	Yes – Area F (Visual and Performing Arts)
Fees	None

COURSE DESCRIPTION

Introduction to Guitar and Electric Bass is an entry level music course that exposes students to the technical, innovative, and expressive aspects of the guitar and electric bass. While studying the fundamental concepts of playing the guitar and bass, students also learn western tonality, music theory, and the great guitarists and bassists of the 20th and 21st centuries. The course emphasizes intervallic reading and also develops the ear with the inclusion of aural training. Students acquire the language of music, including pitch, chord, scale, articulation, meter, and harmonization. Repertoire ranges from blues, to jazz, to rock, including folk songs. Students express themselves creatively through a variety of projects and repertoire and learn how to assess the success of their own work and that of others using vocabulary specific to the course content.

Additional Expectations: This course typically requires 30 minutes of practice each course period, but more practice benefits the student's ability to learn guitar and electric bass.

Special Note: This ensemble meets the "instrument specific core performance requirement" for all guitar majors and minors.

GUITAR II

Course Number	0053
Grade Level	9, 10 ,11, 12
Pre-Requisite	<i>Must be able to play the guitar at an intermediate level. Intro to Guitar & Bass course or instructor approval.</i>
Application and/or Audition Date	None
Grade Scale	Standard
Credits	10
VCHS Graduation Credit	Fine Arts
UC Approval	Yes – Area F (Visual and Performing Arts)
Fees	None

COURSE DESCRIPTION

Guitar II is an intermediate-level music course that immerses students in the technical, innovative, and expressive aspects of the guitar. Building on the fundamental concepts of playing the guitar, the course covers soloing and improvisation, advanced techniques in soloing, becoming an artist (forming a band), recording, advanced use of chords, advanced strumming and fingerstyle, and songwriting. This course also explores music theory and some music history (the great guitarists of the 20th and 21st centuries). Through cutting edge media tools, each week includes a variety of playing techniques such as bending, tapping and harmonics; a thorough assimilation of music theory concepts, such as note identification, chord construction and intervallic reading; a variety of music genres such as rock, jazz and blues; and a panorama of music history through active listening exercises focusing on a famous guitarist. The course emphasizes practical participation. Acoustic guitars are provided to each student to use throughout the course.

Special Note: This ensemble meets the "instrument specific core performance requirement" for all guitar majors and minors.

GUITAR III

Course Number	0046
Grade Level	9, 10, 11, 12
Pre-Requisite	<i>Must be able to play the guitar at an intermediate level. Intro to Guitar & Bass course or instructor approval.</i>
Application and/or Audition Date	<i>Director approval</i>
Grade Scale	<i>Standard</i>
Credits	10
VCHS Graduation Credit	<i>Fine Arts</i>
UC Approval	<i>Yes – Area F (Visual and Performing Arts)</i>
Fees	<i>None</i>

COURSE DESCRIPTION

Guitar 3 is an advanced music course which immerses students in the technical, innovative, and expressive aspects of the guitar. While studying the technical concepts of playing the guitar, this course will also cover music theory (western tonality) and some music history (the great guitarists throughout the last four centuries). Through cutting edge media tools (iPad applications, You Tube projection, textbook/DVD, etc.), each week will include: a variety of playing techniques, such as tapping and bending; opportunities to perform in front of their peers and others; a thorough assimilation of music theory concepts such as note identification, chord construction and intervallic reading; a variety of music genres such as rock, jazz and blues; and a panorama of music history through active listening exercises focusing on famous guitarists. The course emphasizes practical participation with clear communication and demonstration by the instructor. Students must provide their own guitars and will be provided a locker to store them during the day.

Special Note: This ensemble meets the “instrument specific core performance requirement” for all guitar majors and minors.

CONSERVATORY CHORUS

Course Number	0054
Grade Level	9, 10, 11, 12
Pre-Requisite	None
Application and/or Audition Date	None
Grade Scale	Standard
Credits	10
VCHS Graduation Credit	Fine Arts
UC Approval	Pending
Fees	\$200- \$2,500 dependent upon trips planned for the year.

COURSE DESCRIPTION

This performance course aids in the development of proper vocal technique and skills, focusing on improving tone quality, music reading, sight-reading, and ear training abilities. There are opportunities to perform solo and ensemble literature and to rehearse and perform intermediate and advanced choral works. Students may participate in county and state choral events, sing individually and in ensemble, and perform literature in foreign languages.

Additional Expectations: Participation in approximately 10 performances/ festivals throughout the year. Private lessons are strongly encouraged.

Special Note: This ensemble meets the "instrument specific core performance requirement" for all vocal majors and minors.

WORSHIP CHOIR

Course Number	TBD
Grade Level	9, 10, 11, 12
Pre-Requisite	Audition required; instructor approval
Application and/or Audition Date	Auditions held Spring 2018
Grade Scale	Standard
Credits	10
VCHS Graduation Credit	Fine Arts
UC Approval	Yes- Area F (Visual/ Performing Arts)
Fees	\$200

COURSE DESCRIPTION

Students learn the basic elements of performing as a vocal/instrumental unit and are introduced to styles of music from many different genres of worship music. Historical/stylistic study and performance practice also includes classical, jazz, rock, pop, and ethnic. Students in this course lead worship during VCHS chapel services.

Fees include any other special trips/tours.

Special Note: This ensemble meets the "instrument specific core performance requirement" for all guitar majors and minors

CONSERVATORY ENSEMBLE

Course Number	TBD
Grade Level	9, 10, 11, 12
Pre-Requisite	Conservatory Enrollment
Application and/or Audition Date	None
Grade Scale	Standard
Credits	2.5
VCHS Graduation Credit	Fine Arts
UC Approval	None
Fees	\$200-\$3,500 dependent on trips planned this year

COURSE DESCRIPTION

Conservatory Ensemble is the flagship Chorale and Orchestra performance ensemble of the Valley Christian Conservatory of the Arts. This 200 member ensemble aids in the development of proper performance technique and skills, focusing on improving tone quality, music reading, sight reading, and ear training abilities. Serving as the required core class for all music major and minors, Conservatory Ensemble affords students distinctive performance experiences and international travel opportunities in their service as musical ambassadors for the Conservatory of the Arts. Additional Expectations: Participation in approximately 3 performances throughout the year..

VOCAL JAZZ ENSEMBLE

Course Number	0033
Grade Level	9, 10, 11, 12
Pre-Requisite	Audition required; instructor approval; Concurrent enrollment in instrument specific core performance ensemble
Application and/or Audition Date	Auditions held in April 2018
Grade Scale	Standard
Credits	10
VCHS Graduation Credit	Fine Arts
UC Approval	Yes- Area F (Visual/ Performing Arts)
Fees	\$200- \$2,500 dependent upon trips planned for the year.

COURSE DESCRIPTION

This course trains a group of top vocalists performing jazz and pop vocal music— predominantly *a cappella*. Members must be able to sing unaccompanied, read music and stylistically perform jazz and pop genres. Students pay an annual fee for supplies, and festivals. Additional fees include any other special trips/tours.

Additional Expectations: Participation in approximately 10 performances throughout the year. Private lessons are strongly encouraged.

AP MUSIC THEORY

Course Number	0016
Grade Level	9, 10, 11, 12
Pre-Requisite	<i>Ability to read and write musical notation; performance skills in voice or instrument</i>
Application and/or Audition Date	None
Grade Scale	Honors
Credits	10
VCHS Graduation Credit	Fine Arts
UC Approval	Yes- Area F (Visual/Performing Arts)
Fees	None

COURSE DESCRIPTION

This course studies various aspects of melody, harmony, texture, rhythm, form, musical analysis, and composition. Musicianship skills such as dictation and other listening skills, sight-singing, and keyboard harmony are an important part of the theory course. A student's ability to read and write musical notation is fundamental to this course. It is also assumed that students have acquired basic performance skills in voice or on an instrument.

Additional Expectations: This course typically requires 2-3 hours of homework each week.

MUSIC TECHNOLOGY

Course Number	0097
Grade Level	9, 10, 11, 12
Pre-Requisite	Basic computing and music knowledge or instructor approval
Application and/or Audition Date	None
Grade Scale	Standard
Credits	10
VCHS Graduation Credit	Fine Arts
UC Approval	Yes – Area F (Visual & Performing Arts)
Fees	None

COURSE DESCRIPTION

Music Technology provides students with an overview of industry standard music hardware & software applications and stage & event management. This experiential learning approach engages students in multi-modal activities to learn fundamentals of each application. Students apply acquired skills by participating in chapel, Theatre, portfolio submissions, studio recordings, and live events.

Additional Expectations: Participation in after school events is required for successful completion of this course.

NEW MEDIA STUDIES

DESCRIPTION OF EXCELLENCE

The New Media Studies (NMS) program at Valley Christian High School is one of the most diverse media studies programs available at any high school in the country, boasting courses in cinematic arts, 3D animation, radio production, and television broadcasting. We strive to prepare students to be not only excellent story tellers, but also Christian artists who are able to influence and impact those with whom they come in contact.

DISTINCTIVE EXPERIENCE AND ACCOMPLISHMENTS

State of the art equipment and facilities provide students with hands-on experience in all aspects of media production, including production development, cinematography, sound engineering, On-Air DJ experience, film and television directing, and editing. Radio broadcast courses manage and produce programs for KVCH, the world's first high school radio station to broadcast live on the internet. In addition, the NMS department regularly hosts seminars with industry professionals who provide students with further training and insight into the business of media production as well as opportunities to build professional contacts.



NEW MEDIA STUDIES COURSES OFFERED

- The Art of Filmmaking
- Applied Filmmaking
- Advanced Applied Filmmaking
- 3D Film Animation
- Advanced 3D Animation
- Radio Programming
- TV Broadcast Journalism
- Advanced TV Broadcast
- Journalism I
- Journalism II

THE ART OF FILMMAKING

Course Number	1026
Grade Level	9, 10, 11, 12
Pre-Requisite	None
Application and/or Audition Date	None
Grade Scale	Standard
Credits	10
VCHS Graduation Credit	Fine Arts
UC Approval	Yes - Area F (Visual/Performing Arts)
Fees	None

COURSE DESCRIPTION

In this course, students develop a tangible knowledge of the art and history of film. Course work compliments and introduction to film theory with practical assignments involving screenwriting, cinematography, editing, and on-set protocols. Additionally, students will focus on the form of cinema--seeing how a movie is put together and what distinguishes a good and a bad film. Students are able to dissect and interpret a film as they would interpret a page of text.

APPLIED FILMMAKING

Course Number	0044
Grade Level	11, 12
Pre-Requisite	<i>Art of Filmmaking</i>
Application and/or Audition Date	<i>None</i>
Grade Scale	<i>Standard</i>
Credits	10
VCHS Graduation Credit	<i>Elective</i>
UC Approval	<i>Yes - Area F (Visual/Performing Arts)</i>
Fees	<i>None</i>

COURSE DESCRIPTION

This course explores industry standard techniques for filming and editing. Students are exposed to workflows used in the independent film industry, focusing on DSLR cinematography, sound recording techniques, as well as editing and visual effects in the Adobe Creative Cloud. Students continue to develop screenwriting skills developed in Art of Film. Students produce one major short film that they have pitched, scripted, directed, filmed, and edited. Students should expect to film some projects outside of course time, as well as work on a large department wide short film production.

ADVANCED APPLIED FILMMAKING

Course Number	1034
Grade Level	11, 12
Pre-Requisite	<i>Art of Filmmaking</i>
Application and/or Audition Date	<i>None</i>
Grade Scale	<i>Standard</i>
Credits	10
VCHS Graduation Credit	<i>Elective</i>
UC Approval	<i>None</i>
Fees	<i>None</i>

COURSE DESCRIPTION

For students who have completed Art of Film and Applied Filmmaking, this course will focus on the production of a single short film each semester. Students will assume the roles of writers, directors, and producers as they develop a story, script it, break it down for production in terms of props, equipment, locations and actors, secure locations and--working within a predefined budget--acquire the necessary props, costumes and equipment. They will then decide upon a director and assistant director (the other students will be producers), cast the film from the student body, and begin production. Production crew will be drawn from the Applied Filmmaking course. The last part of each semester will be dedicated to editing and delivering the final product.

Students should expect to meet after school every other week and to a couple of weekends per semester to the production of the film.

Limit of 5 students per Section of Applied Filmmaking (Advanced will run at the same time as Applied Filmmaking.).

3D FILM ANIMATION

Course Number	0779
Grade Level	9, 10, 11, 12
Pre-Requisite	None
Application and/or Audition Date	None
Grade Scale	Standard
Credits	10
VCHS Graduation Credit	Elective
UC Approval	Yes- Area F (Visual/ Performing Arts)
Fees	None

COURSE DESCRIPTION

Using the latest 3D animation software, Autodesk® Maya® 3D, students learn modeling, animation, lighting, and designing in this course. Students not only focus on the skills necessary to create and animate but also on using narrative storytelling and animation as a tool to develop and communicate believable characters and settings. Students also explore the industry itself and learn what jobs and careers are available in different areas of animation creation.

ADVANCED 3D ANIMATION

Course Number	0780
Grade Level	9, 10, 11, 12
Pre-Requisite	3D Film Animation or 3D Animation at VCJH
Application and/or Audition Date	None
Grade Scale	Standard
Credits	10
VCHS Graduation Credit	Elective
UC Approval	Yes- Area F (Visual/ Performing Arts)
Fees	None

COURSE DESCRIPTION

Advanced 3D Animation continues development of the skills learned in 3D Film Animation. Students refine their animation skills by exploring ways to bring life to their characters. Students learn and put into practice the twelve principles of animation as laid out by Frank Thomas and Ollie Johnston in *The Illusion of Life*. Additionally, students learn advanced techniques with particle creation and manipulation, as well as basic MEL scripting. Students work primarily in Maya 2015, but assemble and finish scenes in Adobe After Effects and Premiere.

TV BROADCAST JOURNALISM

Course Number	1008
Grade Level	9, 10, 11, 12
Pre-Requisite	None
Application and/or Audition Date	None
Grade Scale	Standard
Credits	10
VCHS Graduation Credit	Elective
UC Approval	None
Fees	None

COURSE DESCRIPTION

This course equips students with hands-on skills in broadcasting. Students learn to report, write, and produce television with an emphasis on accuracy, fairness, and balance. They learn to tell engaging stories that stand out in today's complex media environment. Students learn principles of sound, audio and video editing, mixing, and studio engineering. Students also learn to operate a working television newsroom in various roles, including news writers, producer, director, news, feature and sports reporters, news anchors, cameramen, and control room personnel. This course creates and produces the daily news for the VCHS student body.

Additional Expectations: Students are expected to cover some extracurricular events after school.

ADVANCED TV BROADCAST

Course Number	0038
Grade Level	9, 10, 11, 12
Pre-Requisite	TV Broadcast Journalism
Application and/or Audition Date	None
Grade Scale	Standard
Credits	10
VCHS Graduation Credit	Elective
UC Approval	None
Fees	None

COURSE DESCRIPTION

Students in this course are challenged to hone their skills as a TV journalist. Students produce a monthly “video magazine,” published online on the VCHS student journalism website. Students grow as storytellers and engage today’s media landscape with an emphasis on truth. Pushing past the fundamentals, students master audio and video editing and learn elements of graphic design and studio engineering. Course heavily focuses on developing “on camera talent.” This course contributes to the daily news for the VCHS student body.

Additional Expectations: Students are expected to cover some extracurricular events after school.

JOURNALISM I

Course Number	1003
Grade Level	10, 11, 12
Pre-Requisite	None. Not recommended for freshmen.
Application and/or Audition Date	None
Grade Scale	Standard
Credits	10
VCHS Graduation Credit	Elective
UC Approval	Yes- Area G (General Elective) for 10, 11, 12 only
Fees	None

COURSE DESCRIPTION

Journalism develops and applies advanced skills required by the modern media, including writing, publishing, and presiding over WSDM (Warrior Student Digital Media), the online home of Valley Christian High School journalistic content. In addition to standard news-gathering, writing, editing, and publishing, students learn to think critically about media and the way news is covered, packaged, and delivered, specifically through more sophisticated storytelling models in the realms of multimedia, investigative, and data-based journalism.

Each student will be an active, contributing member of an editorial staff that will produce meaningful content throughout the year. Staff roles will be determined early in the year, and students will have the opportunity to build an array of multimedia skills while learning how to participate on a journalism team modeled after professional newsrooms.

JOURNALISM II

Course Number	1009
Grade Level	11, 12
Pre-Requisite	<i>Digital Journalism I</i>
Application and/or Audition Date	None
Grade Scale	Standard
Credits	10
VCHS Graduation Credit	Elective
UC Approval	Yes- Area G (General Elective)
Fees	None

COURSE DESCRIPTION

This course applies advanced skills required by the modern media, including writing, publishing, and presiding over WSDM (Warrior Student Digital Media), the online home of Valley Christian High School student content. In addition to standard news gathering, writing, editing, and publishing, students learn to think critically about media and the way news is covered, packaged, and delivered, specifically through more sophisticated storytelling models in the realms of multimedia, investigative, and data-based journalism. Students also continue to develop in-depth research, critical thinking, and creative writing skills; they also may be given the opportunity to attend the JEA National Journalism Convention as part of the course.

Additional Expectations: Students are required to meet external production deadlines and invest one to two hours per week of lab time, especially during press week.



PHYSICAL EDUCATION

DESCRIPTION OF EXCELLENCE

The Physical Education department promotes lifelong discipline and good health. While training in diverse sports, athletes learn to exhibit Christian character under the pressure of competition. A central goal of the Human Performance Initiative is to design and implement customized performance plans for each student-athlete in accordance with his/her individual goals and dreams.

DISTINCTIVE EXPERIENCE AND ACCOMPLISHMENTS

The Warriors regularly compete with distinction among the top programs locally and in the state of California, including a State Championship in girls' volleyball along with Central Coast Section titles in golf, baseball and football. The emerging Human Performance Initiative is a unique and flexible way to allow students to dream big dreams, pursue athletic passion, reach fitness goals, discover potential careers in athletic fields, and benefit from exciting leadership opportunities.



PHYSICAL EDUCATION COURSES OFFERED

- Lifetime Fitness
- Foundations of Baseball
- Foundations of Water Polo
- Foundations of Hockey
- Football Performance
- Outdoor Athletic Performance
- Indoor Athletic Performance

LIFETIME FITNESS

Course Number	0501B/ 0501G
Grade Level	9
Pre-Requisite	None
Application and/or Audition Date	None
Grade Scale	Standard
Credits	10
VCHS Graduation Credit	PE/General Elective
UC Approval	None
Fees	\$30 – PE Uniform

COURSE DESCRIPTION

The goal of this course is to promote physically active behavior and a healthy lifestyle so students will remain physically active and aware of their daily choices years after they graduate from Valley Christian High School. Lifetime Fitness is a required course for all freshman with a balance of weekly health sessions and regular physical activity.

Health and wellness education explores topics related to nutrition, stress management, disease prevention, substance abuse, and healthy relationships. The physical component of the course exposes students to a variety of sports and teaches skills necessary to achieve and improve cardiovascular fitness, muscle strength, muscle endurance, body composition, and flexibility. Students develop proper attitudes towards the importance of exercise and personal responsibility in maintaining one's health.

FOUNDATIONS OF BASEBALL

Course Number	0581
Grade Level	10, 11, 12 boys
Pre-Requisite	None
Application and/or Audition Date	None
Grade Scale	Pass/Fail
Credit	10
VCHS Graduation Credit	Elective
UC Approval	None
Fees	None

COURSE DESCRIPTION

This course allows students to learn and further develop baseball skills, utilizing the disciplines taught from our Lifetime Fitness course. This is accomplished through an increased understanding of baseball theory, philosophy, defensive and offensive techniques, defensive and offensive strategies, and team concepts.

FOUNDATIONS OF WATER POLO

Course Number	0589
Grade Level	10, 11, 12
Pre-Requisite	None
Application and/or Audition Date	None
Grade Scale	Pass/Fail
Credit	10
VCHS Graduation Credit	Elective
UC Approval	None
Fees	None

COURSE DESCRIPTION

In this semester-long course, students are introduced to the history and evolution of water polo and related terminology, skills, and common strategies used in the modern game. Students are encouraged to use their spiritual gifts in the context of athletic performance.

FOUNDATIONS OF HOCKEY

Course Number	0593
Grade Level	10, 11, 12
Pre-Requisite	None
Application and/or Audition Date	Spring 2018
Grade Scale	Pass/Fail
Credit	5
VCHS Graduation Credit	Elective
UC Approval	None
Fees	\$700-\$900 for rental of ice time

COURSE DESCRIPTION

This coed semester-long course is designed to improve student hockey skills and provide a full learning spectrum of skill development to give players an extra edge in athletic achievement and the opportunity to realize their potential during the prime development time of their lives.

The program is taught under the direct supervision of the Valley Christian Director of Hockey and supported by former professional hockey players and level 3 certified instructors.

Special Note: Students must provide their own equipment as per USA Hockey guidelines.

FOUNDATIONS OF SOCCER

Course Number	TBD
Grade Level	10, 11, 12
Pre-Requisite	Athletics approval
Application and/or Audition Date	None
Grade Scale	Pass/Fail
Credit	5/5
VCHS Graduation Credit	Elective
UC Approval	None
Fees	None

COURSE DESCRIPTION

In this course, students are taught all aspects of training for soccer. This is a combination of weight room, classroom film study, and on-field movement drills. Students go through four phases: in-season maintenance/film study, strength, power, and speed/quick twitch. All of this ensures that each student athlete is growing to his/her greatest potential for soccer.

FOOTBALL PERFORMANCE

Course Number	0512
Grade Level	10, 11, 12
Pre-Requisite	<i>Athletics approval</i>
Application and/or Audition Date	<i>None</i>
Grade Scale	<i>Pass/Fail</i>
Credit	10
VCHS Graduation Credit	<i>Elective</i>
UC Approval	<i>None</i>
Fees	<i>None</i>



COURSE DESCRIPTION

In this course, students are taught all aspects of training for football. This is a combination of weight room, classroom film study, and on-field movement drills. Students go through four phases: in-season maintenance/film study, strength, power, and speed/quick twitch. All of this ensures that each student athlete is growing to his greatest potential for football.

Football Performance is designed for Varsity and JV Football Players.

OUTDOOR ATHLETIC PERFORMANCE

Course Number	0513
Grade Level	10, 11, 12
Pre-Requisite	<i>Athletics approval</i>
Application and/or Audition Date	<i>None</i>
Grade Scale	<i>Pass/Fail</i>
Credit	5/5
VCHS Graduation Credit	<i>Elective</i>
UC Approval	<i>None</i>
Fees	<i>None</i>



COURSE DESCRIPTION

The advanced performance workouts are intended to provide advanced training for students who intend to participate in interscholastic athletic teams at Valley Christian. First priority in entering courses is given to athletes with an expressed desire to participate on our school teams.

If space is available, spots may be opened for athletes involved in sports outside of Valley Christian. Athletes are grouped into courses based on their sport.

Outdoor Sports Include: Soccer, Baseball, Softball, and Individual Sports

INDOOR ATHLETIC PERFORMANCE

Course Number	0518
Grade Level	10, 11, 12
Pre-Requisite	Athletics approval
Application and/or Audition Date	None
Grade Scale	Pass/Fail
Credit	5/5
VCHS Graduation Credit	Elective
UC Approval	None
Fees	None

COURSE DESCRIPTION

The advanced performance workouts are designed to provide advanced training for students who intend to participate in interscholastic athletic teams at Valley Christian. First priority in entering courses is given to athletes with an expressed desire to participate on our school teams.

If space is available, spots may be opened for athletes involved in sports outside of Valley Christian. Athletes are grouped into courses based on their sport.

Indoor Sports Include: Basketball, Volleyball, and Water Polo





SCIENCE

DESCRIPTION OF EXCELLENCE

God's creative acts provide the foundation for scientific discovery. Students explore the wonder of the laws and principles that govern the universe while developing marketplace skills.

DISTINCTIVE EXPERIENCE AND ACCOMPLISHMENTS

Students demonstrate a grasp of scientific concepts, theories, and calculations through extensive small-group experiments and real-life simulations using state-of-the-art, and industry-standard lab equipment. Students are encouraged to apply their classroom knowledge and intellect to make scientific application through competitions such as the Synopsys Science and Technology Championship and conduct research using equipment such as the Moxi Flow® cytometer and the SpectraMax® M2 Microplate Reader. Students are also equipped and encouraged to take full advantage of the many programs offered through our AMSE after-school programs.



SCIENCE COURSES OFFERED

LIFE SCIENCES

- Biology
- Marine Biology
- Biology Honors
- Anatomy & Physiology
- Anatomy & Physiology Honors
- AP Biology

PHYSICAL SCIENCES

- Astronomy
- Chemistry

- Chemistry Honors
- AP Chemistry
- Physics
- AP Physics 1
- AP Physics C: Mechanics/E&M

INTERDISCIPLINARY SCIENCES

- Integrated Science
- AP Environmental Science
- Scientific Research (listed in electives section of course catalog)

LIFE SCIENCES

BIOLOGY

Course Number	0605
Grade Level	9, 10, 11, 12
Pre-Requisite	Completion of Algebra I. For freshmen, entrance examination to bypass Physical Science.
Application and/or Audition Date	None
Grade Scale	Standard
Credits	10
VCHS Graduation Credit	Science
UC Approval	Yes- Area D (laboratory science)
Fees	None

COURSE DESCRIPTION

This course encompasses ecology, biochemistry, basic chemistry, cell physiology and function, Mendelian genetics, proteins synthesis, biotechnology, origins of life (creation and evolution), botany, and classification of organisms (bacteria through animals). Students are required to follow a comprehensive laboratory program, as well as participate in group activities and projects. Labs include a variety of topics such as enzyme investigations, DNA electrophoresis, plant growth experiments, bacterial growth experiments, and dissections. Dissection is an important component of the second semester study of animal form and function.

Additional Expectations: Students are expected to work hard to learn and understand terminology that will be new to them and apply it to classroom investigations and testing.

MARINE BIOLOGY

Course Number	0652
Grade Level	11, 12
Pre-Requisite	<i>Grade of C or higher in Biology. Course enrollment is limited, and priority will be based on seniority and college admissions needs.</i>
Application and/or Audition Date	None
Grade Scale	Standard
Credits	10
VCHS Graduation Credit	Science
UC Approval	Yes- Area D (laboratory science)
Fees	None

COURSE DESCRIPTION

The marine biology course builds upon and extends biological concepts learned in earlier science courses. Students look in-depth at the physical, chemical, and geological characteristics of the world's oceans. They investigate the structure, functions, behaviors, adaptations, and classification of a variety of marine plants and animals. Students study how energy flows and how matter cycles through the Earth's ocean system, and they investigate the impact of humans on that system. Studies include inquiry based research projects as well as scientific investigations to develop scientific thinking skills. Laboratory activities include dissection, experimentation, data collection, and data analysis.

Additional Expectations: Students are expected to help in the responsibilities associated with maintaining the aquariums.

BIOLOGY HONORS*

Course Number	0611
Grade Level	9, 10, 11, 12
Pre-Requisite	Grade of A in former science courses. Must have completed or be enrolled in Geometry. For freshmen: Entrance examination.
Application and/or Audition Date	None
Grade Scale	Honors*
Credits	10
VCHS Graduation Credit	Science
UC Approval	Yes - Area D (laboratory science)
Fees	Dual Credit

COURSE DESCRIPTION

This rigorous science course covers similar topics to Biology but in greater depth and detail, moving at a rapid pace. Students apply the information learned from lectures and readings by participating in engaging, hands-on activities such as dissections, a wide variety of experiments and activities, a field trip to the Monterey Bay Aquarium, and large-scale projects. In addition, students participate in numerous group activities (Crime Scene Investigation Lab, for example) that serve to apply the information learned in course to real-life scenarios.

Additional Expectations: Students should be self-motivated and have well-developed levels of reading comprehension and critical reading skills. Quizzing and testing are frequent.

*Though internal honors credit is given, the UC does not calculate an honors grade point for this course. Other colleges may assign honors credit.

ANATOMY AND PHYSIOLOGY

Course Number	0610
Grade Level	10, 11, 12
Pre-Requisite	Grade of C or higher in Chemistry.
Application and/or Audition Date	None
Grade Scale	Standard
Credits	10
VCHS Graduation Credit	Science
UC Approval	Yes- Area D (Laboratory Science)
Fees	None

COURSE DESCRIPTION

This course employs a systematic approach to the study of the human body, covering both structure and function. Memorization and application of concepts are key components to success. System topics include basic biochemistry, cells, tissues, skin, nerve function, specialized senses, immunity, the skeletal system, muscle structure and function, blood, and the cardiovascular, respiratory, and digestive systems. Laboratory activities include identification of sense receptors, cardiovascular tests, respiratory system measurements, and other physiology-based labs as well as an extensive cat dissection. The cat dissection focuses on muscle and organ identification as well as engages the students in performing a surgical procedure on their specimens. Guest speakers are used to expose students to a variety of career fields to allow application of their knowledge.

Additional Expectations: Memorization of structures and understanding physiological functions are extremely important, and quizzing and testing is frequent.

ANATOMY AND PHYSIOLOGY HONORS

Course Number	0617
Grade Level	10, 11, 12
Pre-Requisite	Grade of B or higher in Chemistry.
Application and/or Audition Date	None
Grade Scale	Honors
Credits	10
VCHS Graduation Credit	Science
UC Approval	Yes- Area D (laboratory science)
Fees	Dual Credit fees AP exam fee

COURSE DESCRIPTION

Honors Anatomy and Physiology teaches students about each of the eleven systems found in the human body, the intricate relationship between these systems, and the physiological mechanisms by which these systems work, both collaboratively and independently. This course covers the material in much greater detail than the regular Anatomy and Physiology course. Specific goals to be accomplished by each student throughout the course include learning the unique role of each system—both anatomically and physiologically— the role of the independent structures found within each system, the importance of each system in general homeostasis and well-being, and the impacts of disease on each of these systems. Various guest speakers from related fields are brought in to discuss their experiences and expertise as they pertain to the subjects being studied. In addition, this course has an extensive laboratory component. Laboratory time includes various activities such as identification of each of the major structures within each system, reflex and sense exploration, examination of bones and muscles, and an extensive cat dissection.

Additional Expectations: Memorization of structures is extremely important, and quizzing and testing are frequent. An extensive cat dissection project occurs in the second semester.

AP BIOLOGY

Course Number	0643
Grade Level	10, 11, 12
Pre-Requisite	<p>Grade of B or higher in Honors Biology or grade of A in Biology; completion of</p> <p>Chemistry. Students who do not meet these criteria but achieved at least a C in Honors Biology may still take the course, but they must meet with their counselor.</p>
Application and/or Audition Date	None
Grade Scale	Honors
Credits	10
VCHS Graduation Credit	Science
UC Approval	Yes- Area D (laboratory science)
Fees	<p>Dual Credit fees</p> <p>AP exam fee</p>

COURSE DESCRIPTION

This course includes many of the topics covered in Honors Biology, but explores them in greater depth comparable to a college level course. Students will work to apply broad-level concepts to detailed biological principles. Added content includes special attention to plant systems and physiology, animal systems' form and function, genetics, biotechnology, and ecology. The laboratory component includes numerous inquiry-based labs specifically related to content on the AP exam. Special attention is given to lab planning, design, and execution. General topics include chemistry, molecular biology, cells, genetics, biotechnology, viruses, plants, evolution, plant and animal response systems, animal and plant development, and ecology.

Additional Expectations: Students must read and comprehend approximately one chapter of the textbook per class session that we meet. Extensive lab reports are required for most of the lab work completed. Testing is done by units and includes approximately 4-6 chapters.

PHYSICAL SCIENCES

ASTRONOMY

Course Number	0653
Grade Level	11, 12
Pre-Requisite	Completion of Chemistry and Algebra 2 with a C or higher
Application and/or Audition Date	None
Grade Scale	Standard
Credits	10
VCHS Graduation Credit	Science
UC Approval	Yes- Area D (laboratory science)
Fees	None

COURSE DESCRIPTION

Astronomy is the study of our universe on the largest scales. Physics, chemistry, and even biology meet in this course as we study planets, stars, galaxies, black holes, and more. The curriculum covers the history of astronomy, celestial mechanics, telescopes, the solar system, stars, galaxies, and beyond. Students apply critical thinking and mathematical analysis to understand how basic physics concepts shape the universe around us. Material is presented in a blended learning environment that combines classroom lecture, hands-on labs, and computer-aided activities.

CHEMISTRY

Course Number	0615
Grade Level	9, 10, 11, 12
Pre-Requisite	Grade of C or higher in Biology; completion of or enrollment in Algebra II or a more advanced mathematics course.
Application and/or Audition Date	None
Grade Scale	Standard
Credits	10
VCHS Graduation Credit	Science
UC Approval	Yes- Area D (laboratory science)
Fees	None

COURSE DESCRIPTION

Students explore the fundamental principles of chemistry which characterize the properties of matter and how it reacts. Topics will be presented to increase awareness and understanding of the role of chemistry in everyday life and environmental issues. Topics include, but are not limited to: measurement, atomic and molecular structure, electron configuration, chemical bonding, nomenclature, chemical reactions, mole concept, stoichiometry, gases, properties of liquids and solids, solutions and acids and bases. Laboratory work will reinforce topics, develop students' reasoning power, and the ability to apply chemical principles; as well as acquaint students with chemical laboratory techniques and the practical aspects of the scientific method.

Additional Expectations: Chemistry at any level requires proficient math skills and an understanding of the processes of mathematics, problem solving, and algebra. Students are expected to spend sufficient reviewing and practicing problem-solving skills.

CHEMISTRY HONORS*

Course Number	0616
Grade Level	9, 10, 11, 12
Pre-Requisite	Grade of B or higher in Honors Biology or grade of A in Biology is strongly recommended; minimum grade of B in Algebra I; completion of or enrollment in Honors Algebra II or a more advanced mathematics course.
Application and/or Audition Date	None
Grade Scale	Honors*
Credits	10
VCHS Graduation Credit	Science
UC Approval	Yes- Area D (laboratory science)
Fees	Dual Credit fees \$20 Lab Notebook \$30 Chemistry Workbook

COURSE DESCRIPTION

The course covers the same topics as the regular Chemistry curriculum but in greater depth and at an accelerated pace. Honors Chemistry prepares students for subsequent advanced courses in mathematics and science, including AP Chemistry. Students enrolled in the course are expected to develop refined and advanced critical thinking skills and apply those skills in tests, examinations and labs. The course is designed for students who enjoy the sciences and are willing to do a significant amount of independent work to review concepts discussed in the course and has the expectation of high quality work, not necessarily a greater quantity of work. Laboratory work will reinforce topics, develop students reasoning power, and the ability to apply chemical principles; as well as acquaint students with chemical laboratory techniques and the practical aspects of the scientific method. Students will prepare formal laboratory reports and learn this essential science skill.

Additional Expectations: Chemistry requires excellent math skills and an understanding of the processes of mathematics, problem solving, and algebra. There is a strong correlation between student outcomes in math courses and performance in Honors Chemistry, so students should consider their aptitude in mathematics as a guide for future performance in this course. For a student to be successful they will need to review concepts daily and practice problem solving.

*Though internal honors credit is given, the UC does not calculate an honors grade point for this course. Other colleges may assign honors credit.

AP CHEMISTRY

Course Number	0640
Grade Level	10, 11, 12
Pre-Requisite	Grade of B or higher in Honors Chemistry or grade of A in Chemistry with instructor permission. Any student who did not take Honors Chemistry the year prior to AP Chemistry must enroll in the summer seminar.
Application and/or Audition Date	None
Grade Scale	Honors
Credits	10
VCHS Graduation Credit	Science
UC Approval	Yes- Area D (laboratory science)
Fees	Dual Credit fees

COURSE DESCRIPTION

This course is the equivalent to a first-year university chemistry program. It encompasses topics such as molecular orbital theory, thermodynamics, kinetics and reaction mechanisms, chemical equilibrium, acid/base chemistry, electrochemistry, nuclear chemistry, and organic chemistry. Course work emphasizes the theory behind results. Students must be prepared to explain their observations in light of concepts discussed in course. As with any chemistry course, strong math skills are essential to student success. Students are expected to take the AP Chemistry exam in May.

Additional Expectations: Completion of formal homework, fulfillment of reading assignments, and independent review of concepts discussed is expected. Additionally, students must complete 8 laboratory units outside of course time (4 each semester). Each lab takes approximately 1½ hours to complete.

PHYSICS

Course Number	0620
Grade Level	10, 11, 12
Pre-Requisite	Grade of C or higher in Chemistry; completion of Algebra II.
Application and/or Audition Date	None
Grade Scale	Standard
Credits	10
VCHS Graduation Credit	Science
UC Approval	Yes- Area D (laboratory science)
Fees	None

COURSE DESCRIPTION

Physics is a captivating and electrifying look into motion and energy, from sub-atomic particles all the way to stars and galaxies. The curriculum focuses on the mathematical analysis and real-world applications of motion, force, energy, waves, and electricity. In addition to mastery of basic physics concepts, students develop critical thinking and problem-solving skills and consider the role of science in our society today. Material is presented in a blended learning environment that combines classroom lecture, hands-on labs, and computer-aided activities.

AP PHYSICS 1

Course Number	0621
Grade Level	10, 11, 12
Pre-Requisite	Grade of B or higher in Honors Chemistry or grade of A in Chemistry. Grade of B or higher in Honors Algebra II or grade of A in Algebra II. Completion of Trigonometry is strongly recommended.
Application and/or Audition Date	None
Grade Scale	Honors
Credits	10
VCHS Graduation Credit	Science
UC Approval	Yes- Area D (laboratory science)
Fees	AP Test Fees

COURSE DESCRIPTION

AP Physics 1 is an algebra-based, introductory college-level physics course that explores topics such as Kinematics, Newton's laws of motion, torque, rotational motion & angular momentum, gravitation & circular motion, work, energy and power, linear momentum, oscillations, mechanical waves and sound, electrostatics, and DC circuits. Through inquiry-based learning, students develop scientific critical thinking and reasoning skills. AP Physics 1 will develop the skills needed to succeed not only in physics, but in the college classroom where a relentless pursuit of excellence and a confident understanding of subject matter are a must.

Additional Expectations: Algebra, Geometry, and Trigonometry will be the mathematical toolbox used intensively throughout the course to support the analytical examination of the core concepts in physics. Therefore, it is extremely important that students enrolling in this course have the mathematical competency. It is imperative that any student who feels uncomfortable with the required mathematical skills required to succeed in this course talk with the physics teacher before enrollment.

AP PHYSICS C: MECHANICS/E&M

Course Number	0644
Grade Level	11, 12
Pre-Requisite	Grade of B or higher in AP Physics 1 or grade of A in Physics. Completion of or enrollment in AP Calculus AB or BC.
Application and/or Audition Date	None
Grade Scale	Honors
Credits	10
VCHS Graduation Credit	Science
UC Approval	Yes- Area D (laboratory science)
Fees	AP Test Fees

COURSE DESCRIPTION

AP Physics C is equivalent to two semesters of calculus-based, college-level physics courses, especially appropriate for students planning to specialize or major in physical science or engineering. The emphasis in the course is to utilize guided inquiry and student-centered learning to develop conceptual understanding and critical thinking skills.

AP Physics C is a fast-paced and demanding course. The level of theoretical presentations, classroom discussions, assigned problems, and the inclusion of peripheral topics are appropriate for inquisitive students who relish a strong scientific challenge. Students are expected to take the AP Physics C exams (Mechanics and Electricity & Magnetism) in May. The learning style includes classroom lecture, hands-on labs, and computer-aided activities. Introductory differential and integral calculus is used throughout the course.

The first semester explores mechanics topics such as kinematics; Newton's laws of motion; work, energy and power; systems of particles and linear momentum; circular motion and rotation; and oscillations and gravitation. The second semester explores electricity and magnetism topics such as electrostatics; electric circuits; magnetic fields; and electromagnetism.

Additional Expectations: As this is a highly challenging course, students are expected to spend a substantial amount of time practicing problems outside of the classroom as compared with any other regular AP course.

INTERDISCIPLINARY SCIENCES

INTEGRATED SCIENCE

Course Number	0629
Grade Level	9, 10, 11, 12
Pre-Requisite	None
Application and/or Audition Date	None
Grade Scale	Standard
Credits	10
VCHS Graduation Credit	Science
UC Approval	Yes- Area D (laboratory science)
Fees	None

COURSE DESCRIPTION

Integrated science is a survey course designed to help students link science concepts and science skills. This course will provide students with an introduction to biology, chemistry, and physics. Integrated science seeks to give students and understanding of the concepts and principles of science and provides opportunities to develop problem solving and technological skills necessary for the 21st century. This course devotes significant course time to student centered laboratory exercises and activities related to projects. Student participation in laboratory exercises and activities and the development of critical thinking and problem solving skills will be stressed in this course.

AP ENVIRONMENTAL SCIENCE

Course Number	0609
Grade Level	11, 12
Pre-Requisite	Grade of A in Biology and Chemistry or grade of B or higher in Honors/AP Biology and Honors/AP chemistry; Completion of Algebra I.
Application and/or Audition Date	None
Grade Scale	Honors
Credits	10
VCHS Graduation Credit	Science
UC Approval	Yes- Area D (Laboratory Science - Interdisciplinary) Dual Credit fees
Fees	AP Test Fees

COURSE DESCRIPTION

This course is considered an interdisciplinary science, and, as such, students should complete a life and physical science course prior to enrolling in the course. This is a rigorous science course that stresses scientific principles and analysis; this course also includes a laboratory component. In addition, this course acquaints students with the physical, ecological, social, and political principles of environmental science. The scientific method is used to analyze and understand the interrelationships between humans and the natural environment. The course focuses on the causes and effects of pollution and other causes of environmental degradation. Topics include earth's systems and resources, population dynamics, land and water use, energy resources and consumption, and global changes.



SOCIAL SCIENCE

DESCRIPTION OF EXCELLENCE

Through the study of cultures, history, government, and economics, students make connections between actions of the past and current global events, examine ethical questions, refine their worldview, and translate their learning into compassionate action in their lives.

DISTINCTIVE EXPERIENCE AND ACCOMPLISHMENTS

Each year, students in the Social Science department engage in interactive, hands-on, real-world learning through innovative teaching, simulations and creative projects, guest speakers, museum trips, and interdisciplinary collaboration. Students have the opportunity to engage in original research, volunteer in local elections, and apply their understanding of civic and Christian duty through campus outreach clubs and missions trips around the world.



SOCIAL SCIENCE COURSES OFFERED

- Origins of Global Issues
- History and Music
- Modern World History
- Modern World History Honors
- AP Human Geography
- United States History
- AP United States History
- US Government/Economics
- AP US Government/AP Microeconomics

ORIGINS OF GLOBAL ISSUES

Course Number	0257
Grade Level	9, 10
Pre-Requisite	None
Application and/or Audition Date	None
Grade Scale	Standard
Credits	10
VCHS Graduation Credit	Social Science
UC Approval	Yes- Area A (History)
Fees	None

COURSE DESCRIPTION

Every problem in our world today is born out of an intricate interplay of political, economic, social, cultural, environmental, and historical factors. In this innovative course, students examine history and politics through the lens of current events that affect our nation and our world. Through discussion-based, learner-directed instruction, students learn to think critically and write clearly about the underlying patterns and interconnections among global issues. This course is intended for students who want a different approach to traditional history instruction. Designed for students who prefer social science (government, sociology, geography, economics) to narrative history, this course uses the news and student inquiry to guide instruction. By spending the year exploring the modern world in detail and tracing those details to their historic roots, students will be well prepared for Modern World History, Honors Modern World History, or AP Human Geography.

HISTORY AND MUSIC

Course Number	0255
Grade Level	9, 10
Pre-Requisite	<i>This course is designed for students with an interest in music in 9th or 10th grade and will help them develop skills necessary for college prep or AP courses.</i>
Application and/or Audition Date	None
Grade Scale	Standard
Credit	10
VCHS Graduation Credit	Social Science
UC Approval	Yes - Area A (History)
Fees	None

COURSE DESCRIPTION

History and Music is an innovative social science course in which students learn to connect the political, social, economic, and spiritual climate of Western civilization to the music and art it has produced. This course begins in ancient Greece and travels through each time period up to the present. During course, students analyze primary source documents, examine artwork and music from each time period, and actively work in groups to improve academic literacy. In course, skits and presentations are designed so that students live out historical events. History and Music celebrates the gift of music from God as an outlet for creative expression and how the aesthetic of art changes as the times change.

Although this course is open to all students, it is strongly recommended for conservatory music minors and is required for music majors.

MODERN WORLD HISTORY

Course Number	0215
Grade Level	10
Pre-Requisite	None
Application and/or Audition Date	None
Grade Scale	Standard
Credits	10
VCHS Graduation Credit	Social Science
UC Approval	Yes- Area A (History)
Fees	None

COURSE DESCRIPTION

Beginning in the Renaissance and continuing through the modern period, Modern World History examines historical eras through literature, science, theology, economics, and art. Specific topics include the Industrial Revolution, globalization, and the economic philosophies of capitalism, socialism, communism, and mercantilism/imperialism. Through creative hands-on projects, debates, primary source documents, and more, students explore the web of events that shaped our world today and learn how the actions of individuals can impact the course of world history.

MODERN WORLD HISTORY HONORS*

Course Number	0256
Grade Level	9, 10
Pre-Requisite	Grade of B or higher in Honors Ancient World History or Origins of Global Issues. Concurrent enrollment in Honors English 10 is strongly recommended.
Application and/or Audition Date	None
Grade Scale	Honors*
Credits	10
VCHS Graduation Credit	Social Science
UC Approval	Yes- Area A (History)
Fees	None

COURSE DESCRIPTION

This course begins with the Renaissance and continuing through the modern period, it examines philosophy, theology, history, economics, the sciences, and art in order to gain a comprehensive understanding of world events. Students learn to look beyond the textbook to various other means of discovering history. They are introduced to the new historicist approach of study, which incorporates literature, art, film, and comics in order to explore social history and the common people. This course serves as preparation for future AP courses in the social sciences.

*Though internal honors credit is given, the UC does not calculate an honors grade point for this course. Other colleges may assign honors credit.

AP HUMAN GEOGRAPHY

Course Number	0246	COURSE DESCRIPTION <p>The purpose of this college-level introductory course is to introduce students to the systematic study of patterns and processes that have shaped human understanding, use, and alteration of the Earth's surface. Students learn to employ spatial concepts and landscape analysis to examine human socioeconomic organization and its environmental consequences. They also learn about the methods and tools geographers use in their research and applications. Upon successful completion of the course, students should have developed skills that enable them to interpret maps, analyze geospatial data, and understand and explain the implications of associations and networks among phenomena in places. Students should also be able to recognize and interpret the relationships among patterns and processes at different scales of analysis, define regions and evaluate the regionalization process, and characterize and analyze changing interconnections among places.</p>
Grade Level	10, 11, 12	
Pre-Requisite	Grade of B or higher in Honors Modern World History or grade of A in Origins of Global Issues. Students who do not meet this requirement must meet with their counselor. Because of the rigorous writing requirements for this course, a grade of B or higher in English is strongly recommended.	
Application and/or Audition Date	None	
Grade Scale	Standard	
Credits	10	
VCHS Graduation Credit	Social Science	
UC Approval	Yes- Area A (History)	
Fees	AP exam fee	

U.S. HISTORY

Course Number	0220
Grade Level	11
Pre-Requisite	None
Application and/or Audition Date	None
Grade Scale	Standard
Credits	10
VCHS Graduation Credit	Social Science
UC Approval	Yes- Area A (History)
Fees	None

COURSE DESCRIPTION

This course explores the major events that have shaped the United States from reconstruction to the present. Through historical simulations, primary source document analysis, debate, and discussion, students learn to recognize cause and effect as both relate to history. Students also learn to identify major historical turning points and develop historical interpretations of the American past. Through an innovative family research project, students explore their own personal place in US history and learn how an individual can help shape the course of a nation.

Students must take a US History course in order to graduate.

AP UNITED STATES HISTORY

Course Number	0202
Grade Level	11
Pre-Requisite	<p>Grade of B or higher in previous honors/AP history course or A in previous history course.</p> <p>Because of the rigorous writing requirements for this course, a grade of B or higher in English is strongly recommended.</p>
Application and/or Audition Date	None
Grade Scale	Honors
Credits	10
VCHS Graduation Credit	Social Science
UC Approval	Yes- Area A (History)
Fees	<p>Dual Credit fees</p> <p>AP exam fee</p>

COURSE DESCRIPTION

This course explores American history while building the analytic skills and content knowledge necessary to deal critically with issues and events in the development of the United States. Commensurate to the rigor of a freshman level college US history course, AP US History prepares students for intermediate and advanced college courses. Through simulations, debate, discussion, and inquiry-based projects, students learn to assess historical materials—their relevance to a given interpretive problem, their reliability, and their importance—and to weigh the evidence and interpretations presented in historical scholarship. AP US History also helps students prepare for decision-making beyond the classroom by developing the skills necessary to arrive at conclusions on the basis of informed judgment and to present reasons and evidence clearly and persuasively in a variety of written formats. Students will be prepared to take the AP exam in May.

Students must take a US History course in order to graduate.

U.S. GOVERNMENT/ECONOMICS PAIRING

The semester-long courses U.S. Government and Economics are paired. Students who enroll in U.S. Government will automatically be enrolled in Economics. **A civics course (government and/or economics) is required for graduation.**

UNITED STATES GOVERNMENT

Course Number	0231
Grade Level	12
Pre-Requisite	None
Application and/or Audition Date	None
Grade Scale	Standard
Credits	5
VCHS Graduation Credit	Social Science/ Civics
UC Approval	Yes, Semester- Area A (History)
Fees	None

COURSE DESCRIPTION

Students learn Constitutional history, the role of the three branches of national government, and the structure of national, state, and local government. Students also study government budget analysis, the voting process, and public choice economics analysis of government programs and special interest groups. Through a variety of teaching methods including lecture, simulations, group activities, discussion, and debates, this course prepares students to participate in the American political system as part of an informed electorate.

ECONOMICS

Course Number	0230
Grade Level	12
Pre-Requisite	None
Application and/or Audition Date	None
Grade Scale	Standard
Credits	5
VCHS Graduation Credit	Social Science/ Civics
UC Approval	Yes, Semester- Area G (General Elective – History/Social Science)
Fees	None

COURSE DESCRIPTION

Students learn about the “economic way of thinking” and the applications of this reasoning to their daily lives. This is not a course in business, personal finance or investing, but rather an investigation of fundamental concepts of economics such as scarcity, opportunity cost and marginal analysis, the role of prices in allocating goods and services, applications of the supply and demand model to various public policy issues, market structures and antitrust policies, environmental economics, and the role of the Federal Reserve and money.

AP U.S. GOVERNMENT & POLITICS/AP MICROECONOMICS PAIRING

The semester-long courses AP U.S. Government and AP Microeconomics (see course description on following page) are paired. Students who enroll in AP U.S. Government and Politics will automatically be enrolled in AP Microeconomics. **A civics course (government and/or economics) is required for graduation.**

AP UNITED STATES GOVERNMENT & POLITICS

Course Number	0204
Grade Level	12
Pre-Requisite	Grade of B or higher in AP US History or A in previous history course. Because of the rigorous writing requirements for this course, a grade of B or higher in English is strongly recommended. Previous experience suggested.
Application and/or Audition Date	None
Grade Scale	Honors
Credit	5
VCHS Graduation Credit	Social Science/ Civics
UC Approval	Yes, Semester- Area A (History – Civics/American Government)
Fees	Dual Credit fees AP exam fee

COURSE DESCRIPTION

This course focuses on the state of politics in the United States, as well as looking at the structure of the U.S. government. Students learn about the various agencies and institutions that make up the government and learn to describe how their interactions influence the people as a whole and, conversely, how the people are able to influence the government. Through simulations and discussions, students examine case studies from the U.S. These discussions and simulations enable students to gain an understanding of the institutions, groups, beliefs, and ideas that make up the American political environment. This course will help students attain the skills and knowledge they need in order to understand the shifting political climate. Students also learn how the U.S. both influences the world and how events around the world affect the United States. This semester-long course prepares students to take the AP U.S. Government examination in May.

AP U.S. GOVERNMENT & POLITICS/AP MICROECONOMICS PAIRING

The semester-long courses AP U.S. Government (see course description on previous page) and AP Microeconomics is paired. Students who enroll in AP Microeconomics will automatically be enrolled in AP U.S. Government and Politics. **A civics course (government and/or economics) is required for graduation.**

AP MICROECONOMICS

Course Number	0240
Grade Level	12
Pre-Requisite	<p><i>Grade of B or higher in AP US History or A in US History.</i></p> <p><i>Because of the rigorous writing requirements for this course, a grade of B or higher in English is strongly recommended.</i></p> <p><i>Previous AP experience advised, however, is not mandatory</i></p>
Application and/or Audition Date	None
Grade Scale	Honors
Credits	5
VCHS Graduation Credit	Social Science/ Civics
UC Approval	Yes, Semester- Area G (General Elective – History/Social Science)
Fees	AP exam fee

COURSE DESCRIPTION

Economics can be defined as the study of exchange given certain institutional arrangements, or it can be viewed as the study of human action—people making choices. This university-level, semester course focuses on microeconomics concepts.

Through a variety of teaching methods including lecture, simulations, group activities, discussions, and debates, students explore microeconomic topics, including fundamental concepts such as scarcity and opportunity cost, the role of prices in allocating goods and services, applications of supply and demand to public policy issues, public choice analysis, public goods theory, externalities, and market structures.



BUSINESS & TECHNOLOGY

DESCRIPTION OF EXCELLENCE

The business and technology department's program is designed to create academic opportunities for students to develop their 21st century skill grounded in biblical principles. Intentional in developing critical thinkers, students develop their God-given leadership skills to become change makers in the field of business, technology, engineering, and communications.

DISTINCTIVE EXPERIENCE AND ACCOMPLISHMENTS

Building upon the foundational learning in core subjects in business, technology, engineering, and communications, our students extend their learning to the next level through real world applications and hands-on/project based learning through co-curricular programs. The programs include the President's Business Challenge, DECA, Quest Incubator, Speech and Debate, and Model Rocketry.



BUSINESS AND TECHNOLOGY COURSES OFFERED

- Introduction to Computer Programming
- AP Computer Science A
- iPad Technical Support Internship
- PLTW: Introduction to Engineering
- PLTW: Principles of Engineering
- PLTW: Aerospace Engineering
- Introduction to Entrepreneurship
- Advanced Business Honors
- Speech
- Debate

INTRODUCTION TO COMPUTER PROGRAMING

Course Number	0710
Grade Level	9, 10, 11, 12
Pre-Requisite	Grade of B or better in Algebra I
Application and/or Audition Date	None
Grade Scale	Standard
Credits	10
VCHS Graduation Credit	Elective
UC Approval	Yes- Area G (General Elective – Math-CompSci)
Fees	None

COURSE DESCRIPTION

This course introduces students to computer programming and the steps required to build applications that will solve problems and automate tasks. Many assignments will require thinking through processes and building flow diagrams. These will then be used as a blueprint for writing code. Several languages will be used throughout the year as the entry point for learning programming. Concepts will include decision processing, array handling, and the use of various types of data. Students who have minimal computer programming experience are encouraged take this course before taking AP Computer Science A. This class utilizes an online curriculum for delivery of content.

AP COMPUTER SCIENCE A

Course Number	0757
Grade Level	9, 10, 11, 12
Pre-Requisite	<p><i>Prior exposure to computer programming is needed to succeed in this course.</i></p> <p><i>Introduction to Computer Programming is recommended. For students who have not taken Intro to Computer Programming, speak to the instructor</i></p>
Application and/or Audition Date	None
Grade Scale	Honors
Credits	10
VCHS Graduation Credit	Elective
UC Approval	Yes- Area G (General Elective-Math-CompSci)
Fees	AP exam fee

COURSE DESCRIPTION

This course covers basic and advanced topics of Java programming—including types, methods, conditionals, strings, and objects—in preparation for the AP Computer Science A exam. Students design and implement solutions to problems by writing, running, and debugging computer programs using algorithms and data structures. Students also recognize the ethical and social implications of computer use.

Additional Expectations: As with other advanced academic courses, students can expect two to three hours of homework per week, including programming assignments. This class utilizes an online curriculum for delivery of content

IPAD TECHNICAL SUPPORT INTERNSHIP

Course Number	0716
Grade Level	9, 10, 11, 12
Pre-Requisite	Instructor approval.
Application and/or Audition Date	None
Grade Scale	Standard
Credits	10
VCHS Graduation Credit	Elective
UC Approval	No
Fees	None

COURSE DESCRIPTION

Interns are on the front lines of student iPad support and are expected to help students with their use and application of iOS settings, iOS productivity and creativity Apps, file and data management, digital learning workflow, and common student functions such as communication, planning and organization, eReading, note taking, and Internet research. Students are trained in customer service and communication skills, troubleshooting skills, and escalating student help requests to the next point of support when necessary. Interns also contribute support articles to an iPad knowledge base and tips to an iPad blog. Interns are expected to be model digital citizens and learners. Students work directly for the VCS IT department during one of the eight periods of the school day or afterschool. There is also a summer internship available.

Additional Expectations: Interns also participate in a approximately 3-5 VCHS events during the school year, including registration day, Junior High LOST Night, and a teacher in-service.

PLTW: INTRODUCTION TO ENGINEERING DESIGN

Course Number	0776
Grade Level	9, 10, 11, 12
Pre-Requisite	Grade of B or better in Algebra I
Application and/or Audition Date	None
Grade Scale	Standard
Credits	10
VCHS Graduation Credit	Elective
UC Approval	Yes- Area G (General Elective - Interdisciplinary)
Fees	None

COURSE DESCRIPTION

This course exposes students to the design process, research, and analysis used in engineering. Students learn about global and human impacts and how to use the standards and technical documentation of engineering to address those impacts. Students also learn about the importance of teamwork and clear communication when using engineering solutions. Students use 3D solid modeling design software to help them formulate solutions to proposed problems. The skills taught culminate in an ability to effectively document work and communicate solutions to peers and members of the professional community.



PLTW: PRINCIPLES OF ENGINEERING

Course Number	0777
Grade Level	9, 10, 11, 12
Pre-Requisite	<p><i>Must have completed or currently be enrolled in Algebra II and have completed Intro to Engineering Design;</i></p> <p><i>Algebra II Honors recommended</i></p>
Application and/or Audition Date	None
Grade Scale	Standard
Credits	10
VCCHS Graduation Credit	Elective
UC Approval	Yes- Area G (General Elective - Interdisciplinary)
Fees	None

COURSE DESCRIPTION

This course is for students who are serious about pursuing a possible future in engineering. This survey course exposes students to major concepts they will encounter in a post-secondary engineering course. This survey introduces mechanisms, energy sources, electronic circuits, thermodynamics, statics, material properties, structural design, control systems, and kinematics. Students employ engineering and scientific concepts to solve design problems. Students develop problem-solving skills, document their work, and communicate solutions to peers and members of the professional community.



PLTW: AEROSPACE ENGINEERING (AE)

Course Number	0774
Grade Level	10, 11, 12
Pre-Requisite	<i>Must have completed or currently be enrolled in Algebra II and have completed Introduction to Engineering or Principles of Engineering</i>
Application and/or Audition Date	None
Grade Scale	Standard
Credits	10
VCHS Graduation Credit	Elective
UC Approval	Yes- Area G (General Elective - Interdisciplinary)
Fees	\$150

COURSE DESCRIPTION

AE explores the evolution of flight, navigation and control, flight fundamentals, aerospace materials, propulsion, space travel, and orbital mechanics. In addition, this course presents alternative applications for aerospace engineering concepts. Students analyze, design, and build aerospace systems and apply knowledge gained throughout the course in a final presentation about the future of the industry and their professional goals.

Additional Expectations: Students enrolling in the Aerospace Engineering course are required to participate in the AMSE Rocketry after school program. The Rocketry program is the hands-on, applied learning lab that extends beyond the classroom. Students are required to attend two days a week (4 hours/week total) in the lab..



INTRODUCTION TO ENTREPRENEURSHIP

Course Number	0907
Grade Level	9, 10, 11, 12
Pre-Requisite	Course enrollment is limited and priority will be based on seniority and previous entrepreneurial experience.
Application and/or Audition Date	None
Grade Scale	Standard
Credit	10
VCHS Graduation Credit	Elective
UC Approval	Yes- Area G (College Preparatory Elective - Interdisciplinary)
Fees	\$250

COURSE DESCRIPTION

The introduction to Entrepreneurship course provides students in grades 9-12 with the knowledge and skills, both hard and soft, required to succeed in business, entrepreneurship, and life. Similar to an Executive MBA Program, the course covers subjects and issues that are paramount importance to Christian leaders in both for profit and not for profit organizations. Utilizing a blended learning approach, the instructor utilizes a combination of traditional instruction and online curriculum for effective delivery of content

Topics include: Business Formation, Ethics, Finance and Accounting, Product/Customer Development, Marketing, Competition, Sales, Marketing, Distribution

As part of the course, students will participate in the **President's Business Challenge (PBC)**. The PBC is a year-long, project-based learning program that promotes and supports entrepreneurship by providing Valley Christian High School students with a platform for developing the entrepreneurial mindset and skillset necessary to create and launch a startup company.

Students learn how to **ideate, innovate, iterate, pivot** and **"get out of the building"** in their quest to develop customers for their product or service as part of their search for validation of their business model. Insights into these processes are gleaned from detailed readings in the following books: [The Startup Owner's Manual](#), [The Four Steps to the Epiphany](#), [The Innovator's Mindset](#), [Business Model Generation](#), and [The Lean Startup](#).

Using the project based learning process students will gain valuable experience in teamwork and collaboration and will learn to problem solve and innovate as they work on their real-life business solution. In the process, students will interact with top business leaders in Silicon Valley through personal mentoring and a speaker series.

Finally, students in this UC approved course will complete four entrepreneurship plans that prepare them to participate in DECA competitive events at the district, state and international levels.

ADVANCED BUSINESS HONORS

Course Number	0908
Grade Level	10, 11, 12
Pre-Requisite	<i>Intro to Entrepreneurship (exceptions may apply)</i>
Application and/or Audition Date	<i>Required</i>
Grade Scale	<i>Honors</i>
Credit	10
VCHS Graduation Credit	<i>Elective</i>
UC Approval	<i>Yes- Area G (College Preparatory Elective - Interdisciplinary)</i>
Fees	<i>TBD</i>

COURSE DESCRIPTION

The Advanced Business course provides students in grades 10-12 with an in-depth and comprehensive analysis of the topics and skills required to succeed as Christian leaders in business, entrepreneurship and life. Students will build upon the lessons and skills learned in the Introduction to Entrepreneurship Course. The Case Study Approach from Harvard Business School will be a major component of class discussions and a HBS Case will be the sole topic of discussion during the final exam.

Topics include:

- Accounting II
- Advanced Marketing
- Advertising
- Business Law
- Human Resources Management
- International Business
- Professional Communications (Industry Certification available from Southwest Airlines)
- Public Speaking
- Practicum in Marketing

As part of the course, students will participate in the PBC Incubator program. The PBC Incubator Program is a year-long, project-based learning program that provides an opportunity for students to work directly with a network of mentors to work on an early stage startup. Students have the option to launch their previously vetted PBC startup or intern for a Quest Institute internship opportunity.

Through a project based learning process students will gain invaluable experience in teamwork and collaboration. They will employ strategic long-term thinking to solve problems that organizations of all sizes encounter in their daily operations and in their quest to become profitable, socially responsible industry leading firms.

As in the Introduction to Entrepreneurship course, students will interact with top business leaders in Silicon Valley through a variety of forums including personal networking, "lunch and learn" small group discussions and field trips.

SPEECH/DEBATE PAIRING

The semester-long courses Speech and Debate are paired. Students who enroll in Speech will automatically be enrolled in Debate.

SPEECH

Course Number	0127
Grade Level	9, 10, 11, 12
Pre-Requisite	None
Application and/or Audition Date	None
Grade Scale	Standard
Credits	5
VCHS Graduation Credit	Elective
UC Approval	Yes- Area G (General Elective – English)
Fees	Dual Credit fees

COURSE DESCRIPTION

Designed to improve students' ability to function in any speaking situation, this semester course emphasizes the basic concepts of speaking as a transfer of understood messages, particularly as communication between a single speaker and an audience. Students learn how to prepare and present extemporaneous speeches and develop active listening skills as well as negotiation skills imperative for the business world. In addition, students plan persuasive speeches and receive training in research methods. This course is excellent for building presentation skills.

DEBATE

Course Number	0126
Grade Level	9, 10, 11, 12
Pre-Requisite	None
Application and/or Audition Date	None
Grade Scale	Standard
Credits	5
VCHS Graduation Credit	Elective
UC Approval	Yes- Area G (General Elective – English)
Fees	Dual Credit fees

COURSE DESCRIPTION

This semester course builds upon the skills learned in speech. Students develop reasoning skills and practice formal and informal argumentation and persuasion. The course content includes an analysis of standard debate techniques (traditional, cross-examined, Lincoln-Douglas). The goal of this course is to enable students to reach decisions based on reasoning and evidence. The skills learned in debate pair well with Applied Ethics and Philosophy of Religion.

Additional Expectations: Students have the opportunity to enter local speech and debate competitions.



THEATRE ARTS

DESCRIPTION OF EXCELLENCE

Students cultivate their God-given creative talents through involvement in theoretical and practical aspects of theatre arts. Training explores a variety of performance methods, design techniques, and industry standards for the creation of theatre while facilitating regular application of Christian values to artistic expression.

DISTINCTIVE EXPERIENCE AND ACCOMPLISHMENTS

Our progressive arts training program is one of the finest in the US, recognized by *Stage Directions Magazine* as one of the top 6 theatre programs in the country (2009). In 2014, the production of *Into the Woods* swept the California Musical Theatre Honors Program, winning Best Overall Production, Best Actor, Best Actress, and Best Supporting Actress. Diverse curriculum and a state-of-the-art theatre facility provide students with hands-on experience in all aspects of theatre production, including performance, costumes, properties, lighting, sound, and production management.



THEATRE ARTS COURSES OFFERED

- Theatre I
- Theatre II
- Theatre II Honors
- Improvisational Theatre
- Musical Theatre
- Technical Theatre I
- Technical Theatre II
- Technical Theatre II Honors
- Advanced Design and Stage Production Internship
- Theatre Theory

THEATRE I

Course Number	0005
Grade Level	9, 10, 11, 12
Pre-Requisite	None
Application and/or Audition Date	None
Grade Scale	Standard
Credits	10
VCHS Graduation Credit	Fine Arts
UC Approval	Yes- Area F (Visual/Performing Arts)
Fees	None

COURSE DESCRIPTION

This course introduces the various aspects of theatre. Students explore styles, methods, and genres through a combination of academic study and active presentation of assigned projects. Coursework includes the development of voice, physical theatre, mental awareness, scene work, lighting, costumes, makeup, script analysis, audition techniques, and theatre history. This course encourages students in their understanding of show production within theatre arts.

Additional Expectations: Some time outside of course is required, including 10 tech hours over 2 semesters.

THEATRE II

Course Number	0004
Grade Level	10, 11, 12
Pre-Requisite	<i>Theatre I, Musical Theatre, Improvisational Theatre, or instructor approval</i>
Application and/or Audition Date	None
Grade Scale	Standard
Credits	10
VCHS Graduation Credit	Fine Arts
UC Approval	Yes- Area F (Visual/Performing Arts)
Fees	None

COURSE DESCRIPTION

This course investigates and develops an intimate working knowledge of theatrical performance. Students continue to explore styles, methods, and genres through academic study and active presentation of assigned projects. Course work includes further study of voice, physical theatre, mental awareness, and theatrical styles.

Scene/monologue work will comprise a major portion of the curriculum, as will script analysis, audition techniques, and theatre history. Students develop a professional understanding of the various components of theatrical production through collaborating closely with the Theatre II Honors and Technical Theatre II Honors courses on projects and performances. This course culminates in the creation of a full-length, student-directed evening of theatre: *Experiments in Comedy and Tragedy*.

Additional Expectations: Students are required to participate in lunchtime performances and evening rehearsals/performances for *Experiments in Comedy and Tragedy*.

THEATRE II HONORS

Course Number	0003
Grade Level	10, 11, 12
Pre-Requisite	<i>Musical Theatre, Improvisational Theatre, or instructor approval</i>
Application and/or Audition Date	None
Grade Scale	Honors
Credits	10
VCHS Graduation Credit	Fine Arts
UC Approval	Yes- Area F (Visual/ Performing Arts)
Fees	None

COURSE DESCRIPTION

This intensive course concerns itself with upper level exploration of the nature and manner of the dramatic arts in both its historical and contemporary manifestations. Students are also expected to learn how to read a script, analyze its thematic structures, discern metaphoric patterns, understand the use of classical symbols, and create a production concept that accurately reflects these practices. In addition, students who have proven their aptitude in the dramatic arts are given the opportunity to create theatre in a professional environment. Students direct Theatre II students and collaborate with the Honors Technical Theatre II course to create “Brown Bag” lunchtime one-act performances. This course culminates in the creation of a full-length, student-directed evening of theatre: *Experiments in Comedy and Tragedy*.

Additional Expectations: Students are required to participate in lunchtime Brown Bag rehearsals and performances and evening rehearsals/performances for *Experiments in Comedy and Tragedy*.

IMPROVISATIONAL THEATRE

Course Number	0062
Grade Level	10, 11, 12
Pre-Requisite	Audition/Instructor Approval
Application and/or Audition Date	Auditions held early March 2015
Grade Scale	Standard
Credits	10
VCHS Graduation Credit	Fine Arts
UC Approval	None
Fees	None

COURSE DESCRIPTION

Tina Fey, Will Ferrell, and Jack Black all did Improv in High School, and so should you! Build your collaborative and creative problem-solving skills while honing your acting chops and laughing until your sides ache. During this project-based course, students learn, practice, and develop different forms of improvisation to perform at lunch “Brown Bag” performances, Chapel, High School Improv competitions, and more.

Additional Expectations: Some time outside of course is required for performances and competition.

MUSICAL THEATRE

Course Number	0004A
Grade Level	10, 11, 12
Pre-Requisite	Theatre I or instructor Approval
Application and/or Audition Date	None
Grade Scale	Standard
Credits	10
VCHS Graduation Credit	Fine Arts
UC Approval	Yes- Area F (Theatre)
Fees	None

COURSE DESCRIPTION

This course applies the acting techniques learned in Theatre I to the performance of musical theatre. Students continue to examine acting styles and methods; they also study the fundamentals of vocal and physical performance for musical theatre, along with the basics of music theory and etiquette when interacting with an accompanist. Performances comprise a major portion of the coursework and include solos, duets, and short scenes from contemporary and classic musical theatre.

TECHNICAL THEATRE I

Course Number	0006
Grade Level	9, 10, 11, 12
Pre-Requisite	None
Application and/or Audition Date	None
Grade Scale	Standard
Credits	10
VCHS Graduation Credit	Fine Arts
UC Approval	Yes- Area F (Visual/ Performing Arts)
Fees	None

COURSE DESCRIPTION

This course explores all areas of theatrical design, offering practical, hands-on experience in the design of scenery, lighting, sound, makeup and costumes. This course familiarizes students with the basic components, tools, and theory of technical theatre, including construction and maintenance of theatre sets and facilities.

Additional Expectations: Some time outside of course is required.

TECHNICAL THEATRE II

Course Number	0007
Grade Level	10, 11, 12
Pre-Requisite	Tech Theatre I
Application and/or Audition Date	None
Grade Scale	Standard
Credit	10
VCHS Graduation Credit	Fine Arts
UC Approval	Yes- Area F (Visual/Performing Arts)
Fees	None

COURSE DESCRIPTION

This course leads students to develop an intermediate understanding of technical theatre and theatrical design. Students continue to develop practical skills in the design of scenery, lighting, sound, make-up, and costumes. This course introduces students to the fundamentals of metalwork and welding, while further developing knowledge of the components, tools, and theory of technical theatre. Course work applies intermediate techniques of design, drafting, and set construction, focusing on computer design software in all technical areas. Practical experience is gained through the design, construction, and maintenance of theatre sets and facilities.

Additional Expectations: Some time outside of course is required.

TECHNICAL THEATRE II HONORS

Course Number	0008
Grade Level	10, 11, 12
Pre-Requisite	<i>Technical</i> <i>Theatre I; instructor approval.</i>
Application and/or Audition Date	None
Grade Scale	Honors
Credits	10
VCHS Graduation Credit	<i>Fine Arts</i>
UC Approval	<i>Yes- Area F (Visual/Performing Arts)</i>
Fees	None

COURSE DESCRIPTION

This is a repeatable, upper-level elective that concerns itself with advanced design and production for the theatre. Students are expected to have already developed a working knowledge of both stagecraft and the art of theatre. This course focuses on further developing these skills, culminating in the ability to apply theatrical design to productions created by the Honors Theatre II course. Students continue to develop advanced skills in woodworking, metalworking, set design, prop design, costume design, stage makeup, stage lighting, and sound design, as well as developing necessary collaborative production skills. Students also study, critique, and emulate both classical and contemporary professional design. Students are expected to learn how to read a script, analyze its thematic structures, discern metaphoric patterns, understand the use of classical symbols, and create a design concept that accurately reflects these practices. In addition, students who have proven their aptitude in the dramatic arts are given the opportunity to create theatre in a professional environment. Students collaborate with the Honors Theatre II course to create weekly "Brown Bag" lunchtime one-act performances. This course culminates in the creation of a full-length, student-designed and directed evening of theatre called *Experiments in Comedy and Tragedy*.

Additional Expectations: Students are required to participate in lunchtime performances and evening rehearsals/performances for *Experiments in Comedy and Tragedy*.

ADVANCED DESIGN AND STAGE PRODUCTION INTERNSHIP

Course Number	1013
Grade Level	11, 12
Pre-Requisite	<i>Technical Theatre I, II, II (H); instructor approval.</i>
Application and/or Audition Date	March 2015
Grade Scale	Standard
Credits	10
VCHS Graduation Credit	Fine Arts
UC Approval	No
Fees	None

COURSE DESCRIPTION

This is a repeatable, upper-level elective that concerns itself with the design process of the different productions offered throughout the year. Students learn to apply knowledge acquired during prerequisite courses in project-based opportunities. Interns work closely with both the directors and technical directors on various shows to produce the necessary designs used during the production process. This opportunity offers students experience in set, prop, and video design and development. Students are expected to work in a professional environment, attend production meetings, and provide necessary materials, information, and design work on a given schedule. The opportunity allows interns to develop the design portfolios and resumes that can be used for career and college advancement.

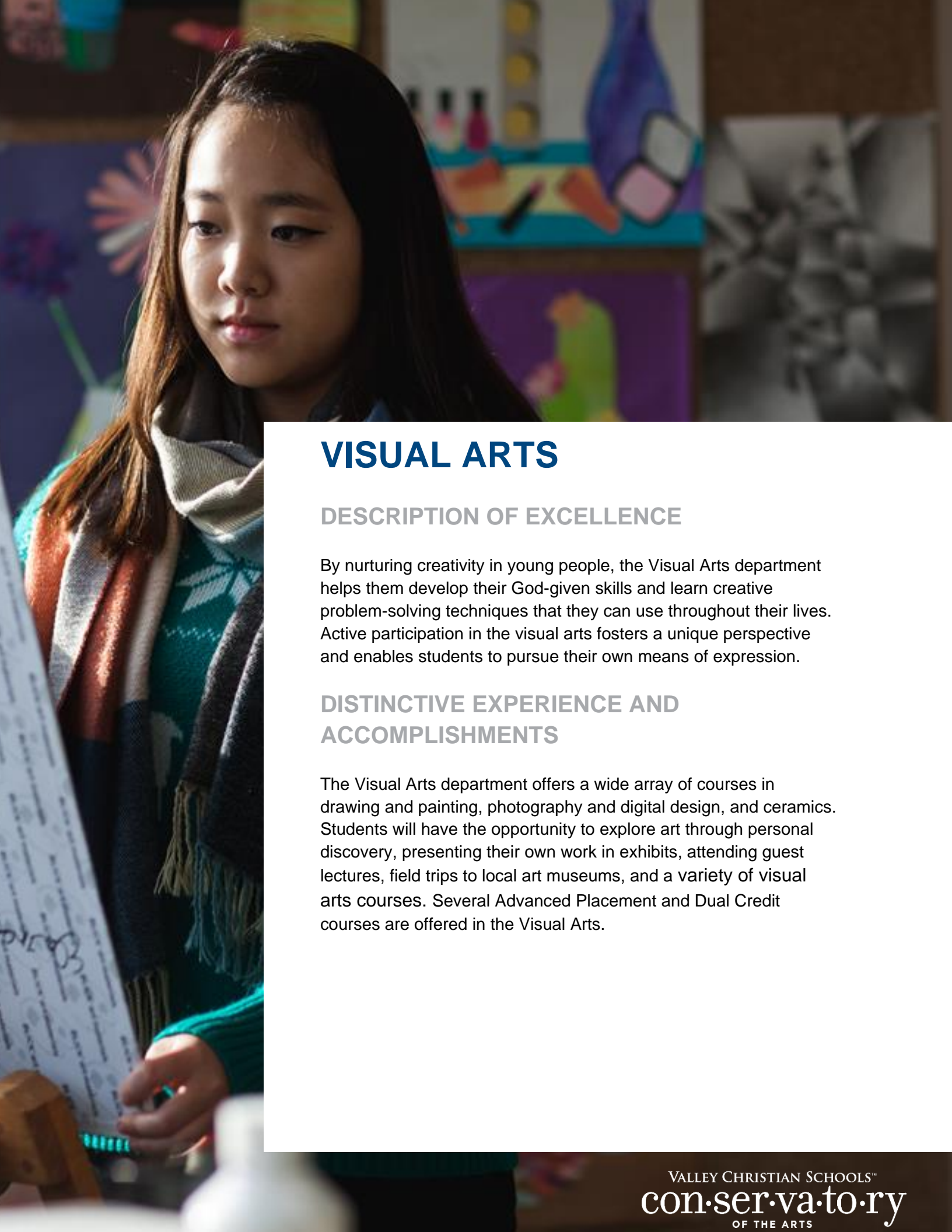

VISUAL ARTS

DESCRIPTION OF EXCELLENCE

By nurturing creativity in young people, the Visual Arts department helps them develop their God-given skills and learn creative problem-solving techniques that they can use throughout their lives. Active participation in the visual arts fosters a unique perspective and enables students to pursue their own means of expression.

DISTINCTIVE EXPERIENCE AND ACCOMPLISHMENTS

The Visual Arts department offers a wide array of courses in drawing and painting, photography and digital design, and ceramics. Students will have the opportunity to explore art through personal discovery, presenting their own work in exhibits, attending guest lectures, field trips to local art museums, and a variety of visual arts courses. Several Advanced Placement and Dual Credit courses are offered in the Visual Arts.



VISUAL ARTS COURSES OFFERED

- Ceramics I
- Ceramics II/III
- Art I
- Art II
- Art III
- AP Studio Art: Drawing
- Introduction to Graphic Design
- AP Studio Art: 2D Design
- Photographic Design I
- Photographic Design II
- Photographic Design Studio
- AP Art History
- Yearbook

CERAMICS I

Course Number	0079
Grade Level	9,10, 11, 12
Pre-Requisite	<i>Space is limited, and priority is given based on Conservatory Visual Arts Major/Minor, graduation needs, and seniority.</i>
Application and/or Audition Date	None
Grade Scale	Standard
Credits	10
VCHS Graduation Credit	Fine Arts
UC Approval	Yes- Area F (Visual Arts)
Fees	\$50 and Dual Credit fees

COURSE DESCRIPTION

Ceramics I is an entry level course in basic ceramic and sculpting techniques. The course is an exploration in three dimensional design, which develops an understanding of art elements and principles as they apply to three-dimensional form. Topics covered in this course include the nature of clay bodies, the history of ceramics, basic hand building, wheel throwing, glazing, decorating techniques, and the firing process. Students express themselves creatively through a variety of projects and learn how to assess the success of their own work and that of others using vocabulary specific to the course content.

CERAMICS II

Course Number	0042
Grade Level	10, 11, 12
Pre-Requisite	Grade of C or higher in Ceramics I and instructor approval. Space is limited, and priority is given based on Conservatory Visual Arts Major/Minor, graduation needs, and seniority.
Application and/or Audition Date	None
Grade Scale	Standard
Credits	10
VCHS Graduation Credit	Fine Arts
UC Approval	Yes- Area F (Visual Arts)
Fees	\$50

COURSE DESCRIPTION

Ceramics II is an advanced pottery course where students build upon the skills they have acquired in Ceramics I and/or II. This course is for the student who is motivated to undertake very ambitious work in clay and further their understanding of ceramic art as a means of artistic expression. Ceramics II students who have demonstrated proficiency in the course are given considerable freedom as they pursue their own artistic endeavors guided by the instructor. The goal of this course is to provide students the opportunity to grow as artists in a community of other highly motivated artists. These students produce works in clay that utilize higher order thinking in terms of expressing thoughts, ideas, feelings, and attitudes. Students explain or justify themes and aesthetic decisions, making connections to art history, spirituality, and current events. Projects display advancement in complexity and mastery of the ceramic process.

ART I

Course Number	0020
Grade Level	9, 10, 11, 12
Pre-Requisite	None
Application and/or Audition Date	None
Grade Scale	Standard
Credits	10
VCHS Graduation Credit	Fine Arts
UC Approval	Yes- Area F (Visual Arts)
Fees	\$25

COURSE DESCRIPTION

This course introduces and develops the basic principles of art through drawing and design and color projects. Students complete course objectives and assignments using a variety of media and techniques. Graphite, pen and ink and scratchboard are used to strengthen black-and-white drawing skills. Students train in the use of acrylics in addition to other color media as they learn color theory and painting. All work for this basic course is two-dimensional. This course includes participation in the student art exhibit each spring

ART II

Course Number	0021
Grade Level	9, 10, 11, 12
Pre-Requisite	Art I or instructor recommendation
Application and/or Audition Date	None
Grade Scale	Standard
Credit	10
VCHS Graduation Credit	Fine Arts
UC Approval	Yes- Area F (Visual Arts)
Fees	\$25

COURSE DESCRIPTION

This course includes art history as it relates to various cultures and time periods. Students are expected to work at a more advanced level to display skills acquired in Art I. Students complete complex projects and are given the freedom to select media, refine their techniques and develop individual styles. This course includes an annual field trip to a Bay Area art museum and participation in the student art exhibit each spring.

ART III

Course Number	0024
Grade Level	10, 11, 12
Pre-Requisite	Grade of C or higher in Art II.
Application and/or Audition Date	None
Grade Scale	Standard
Credit	10
VCHS Graduation Credit	Fine Arts
UC Approval	Yes- Area F (Visual Arts)
Fees	\$25

COURSE DESCRIPTION

This course further develops and hones skills in individual areas of interest as students explore a wide variety of mediums and techniques. Students assemble a portfolio of works to use when applying to an art college or liberal arts university. This course can be taken in preparation for AP Studio Art. Art III includes participation in the student art exhibit each spring.

AP STUDIO ART: DRAWING

Course Number	0026
Grade Level	10, 11, 12
Pre-Requisite	Grade of C or higher in Art III.
Application and/or Audition Date	None
Grade Scale	Honors
Credits	10
VCHS Graduation Credit	Fine Arts
UC Approval	Yes- Area F (Visual Arts)
Fees	\$25

COURSE DESCRIPTION

This course guides students to complete a series of college-level projects that reflect an area of interest and emphasis, such as figure studies, illustration, painting, or graphic design. By May of each year, students must complete a portfolio of 24 works suitable for AP submission (AP Drawing Portfolio or Color and Design Portfolio).

Additional Expectations: Work outside of course is required in order to complete the extensive portfolio requirements.

AP STUDIO ART: 2D DESIGN

Course Number	0074
Grade Level	11, 12
Pre-Requisite	Grade of C or higher in Photographic Design II or Art III.
Application and/or Audition Date	None
Grade Scale	Honors
Credit	10
VCHS Graduation Credit	Fine Arts
UC Approval	Yes- Area F (Visual Arts)
Fees	\$25

COURSE DESCRIPTION

This course guides students as they complete a series of college level projects that reflect an area of interest and emphasis; these works can include any combination of 2D drawings, paintings, photographs or graphic design pieces. Students must complete a portfolio of 24 works suitable for AP submission.

Additional Expectations: Work outside of course is required in order to complete the extensive portfolio requirements.

PHOTOGRAPHIC DESIGN I

Course Number	0012
Grade Level	9, 10, 11, 12
Pre-Requisite	None
Application and/or Audition Date	None
Grade Scale	Standard
Credits	10
VCHS Graduation Credit	Fine Arts
UC Approval	Yes- Area F (Visual Arts)
Fees	Personally owned digital camera

COURSE DESCRIPTION

This course explores the practical and artistic uses of today's modern digital cameras. Students learn how to use a digital camera and edit their digital images using the latest image editing software. Students examine the history, theory, and methods of photographic expression, while applying their understanding to the production of their own creative works. Students are exposed to compositional rules and guidelines used in photography. Emphasis is placed upon the elements and principles of art and design.

Additional Expectations: Students are expected to supply their own digital cameras (6 or more mega-pixels suggested) with a removable digital media card.

PHOTOGRAPHIC DESIGN II

Course Number	0013
Grade Level	10, 11, 12
Pre-Requisite	Grade of C or higher in Photographic Design I.
Application and/or Audition Date	None
Grade Scale	Standard
Credits	10
VCHS Graduation Credit	Fine Arts
UC Approval	Yes- Area F (Visual Arts)
Fees	Personally owned DSLR camera

COURSE DESCRIPTION

This course explores the technology, fine arts, and graphic design applications of digital image processing and presentation. This course emphasizes the use of digital cameras and other creative media to generate original images for manipulation with digital imaging and design software

Note: It is highly recommended that students taking this course own or have access to a DSLR camera. A basic understanding of Mac computer environments and Adobe Creative Suite software is also recommended.

PHOTOGRAPHIC DESIGN STUDIO

Course Number	0019
Grade Level	11, 12
Pre-Requisite	Grade of C or higher in Photographic Design II.
Application and/or Audition Date	None
Grade Scale	Standard
Credits	10
VCHS Graduation Credit	Fine Arts
UC Approval	Yes- Area F (Visual Arts)
Fees	Personally owned digital camera

COURSE DESCRIPTION

This course instructs students on the proper ways to photograph on-site activities such as sporting events, family portraits, head-shots for theatre, fundraisers, and benefits. Students work with professional level equipment and are trained in the proper ways to edit and present work for a client. They are exposed to every aspect of the working photographer: marketing their talent, producing a marketable portfolio, scheduling multiple jobs, meeting deadlines, and building and retaining a client base.

Additional Expectations: Students must have a digital camera (6 or more mega-pixels suggested) with a removable digital media card (Compact Flash, Smart Media, Secure Digital or Sony Memory Stick).

AP ART HISTORY

Course Number	0009
Grade Level	10, 11, 12
Pre-Requisite	Visual Art or Social Science
Application and/or Audition Date	N/A
Grade Scale	Honors
Credit	10
VCHS Graduation Credit	Fine Arts
UC Approval	Yes – Area F (Visual Arts)
Fees	AP

COURSE DESCRIPTION

Provides an understanding and knowledge of architecture, sculpture, painting, and other art forms within diverse historical and cultural contexts on an introductory college course level. Students examine and critically analyze major forms of artistic expression from the past and present from a variety of cultures. The course also emphasizes understanding works in context, considering such issues as patronage, gender, and the functions and effects of works of art. Students who have done well on other courses in the humanities, such as history and literature, or in any of the studio arts are especially encouraged to enroll.

GRAPHIC DESIGN

Course Number	TBD
Grade Level	TBD
Pre-Requisite	None
Application and/or Audition Date	N/A
Grade Scale	Standard
Credit	TBD
VCHS Graduation Credit	Fine Arts
UC Approval	Pending
Fees	TBD

COURSE DESCRIPTION

This course will introduce students to graphic design skills using both traditional and digital tools and materials employed in the visual communication industry. The focus will be on finding creative visual solutions to communication problems with emphasis on the elements and principles of design. Students will also be exposed to such topics as color theory, Gestalt principles, and the role of graphic design and the designer in the world today. Students will be utilizing graphics programs including Adobe Photoshop, Illustrator, and InDesign.

YEARBOOK

Course Number	0900
Grade Level	9, 10, 11, 12
Pre-Requisite	None
Application and/or Audition Date	None
Grade Scale	Standard
Credits	10
VCHS Graduation Credit	Elective
UC Approval	None
Fees	None

COURSE DESCRIPTION

This course studies all aspects of yearbook production, including staffing, advertising, story-writing, interviewing, photography, page layout, proofing, and publication requirements. Each student develops proficiency in Yearbook Avenue Design software. The result of the combined efforts of the course is the school yearbook, *Vanguard*.

Additional Expectations: Students are required to meet external production deadlines, sell \$400 in business ads for *Vanguard*, and invest one to two hours per week of lab time, especially during press week.



WORLD LANGUAGE

DESCRIPTION OF EXCELLENCE

The Great Commission in Matthew 28:19 tells us to spread the good news of salvation in Jesus Christ to all nations. The World Language department offers students the opportunity to become proficient in five languages other than English. Communication and cultural understanding are essential skills for success in college, career, and ministry and prepare our students to influence the world for Christ.

DISTINCTIVE EXPERIENCE AND ACCOMPLISHMENTS

Students can join national honor societies and compete for awards and scholarships, as well as join clubs in every language offered. Guest speakers and interaction with the community offer rich experience along with travel opportunities. The study of a World Language prepares students for a successful future.



WORLD LANGUAGE COURSES OFFERED

- American Sign Language I
- American Sign Language II
- American Sign Language III
- American Sign Language IV
- Chinese (Mandarin) I
- Chinese (Mandarin) II
- Chinese (Mandarin) III
- Chinese (Mandarin) IV Honors
- AP Chinese (Mandarin) Language and Culture
- French I
- French II
- French III
- French IV Honors
- Latin I
- Latin II
- Latin III
- Latin IV Honors
- AP Latin
- Spanish I
- Spanish II
- Spanish III
- Spanish III Honors
- Spanish IV
- AP Spanish Language & Culture

The VCHS World Language Department prepares students with comprehensive language study that includes not only e-texts, but also online listening, speaking, games and activities. Students hear authentic pronunciation in classes and online. They use the target languages in context, preparing them to use the languages in real life in our world today and in the future.

World Language Placement Testing

If a student is a native speaker of the language he/she wishes to take, or if a student has extensive experience in the language, that student must take a placement test to evaluate which level is appropriate for him/her. If a student wishes to skip a year of a language, a placement test must be taken to evaluate the level of mastery. Placement tests will be held in mid-July and early August.

AMERICAN SIGN LANGUAGE

The study of American Sign Language (ASL) is a perfect choice for many students. This artful and expressive movement-based language is very effective for those who struggle with the traditional vocabulary and grammar memorization of language learning. The National Census for Deaf Persons estimates that the number of deaf people needing Sign Language numbers from 360,000 to 517,000 in the U.S. alone. Knowledge of ASL gives students valuable preparation for careers in medicine, law, ministry, social work, economics, and education as sign language interpreters and instructors.

AMERICAN SIGN LANGUAGE I

Course Number	0485
Grade Level	9, 10, 11, 12
Pre-Requisite	Grade of C or higher in English. This course has limited space and priority is given to sophomores.
Application and/or Audition Date	None
Grade Scale	Standard
Credits	10
VCHS Graduation Credit	World Language
UC Approval	Yes – E Course (LOTE)
Fees	None

COURSE DESCRIPTION

ASL 1 introduces students to the background and development of the different signing methods along with Deaf culture. Students become proficient at signing through spelling, gestures, and vocabulary necessary for basic communication. This course is highly interactive and project-based, which is ideal for students who learn best through movement (kinesthetic learners). American Sign Language is a recognized foreign language by many colleges and universities.

Additional Expectations: Students are expected to experience Deafness throughout both semesters and integrate ASL into their spiritual understanding.

AMERICAN SIGN LANGUAGE II

Course Number	0492
Grade Level	9, 10, 11, 12
Pre-Requisite	Grade of C or higher in ASL I.
Application and/or Audition Date	None
Grade Scale	Standard
Credits	10
VCHS Graduation Credit	World Language
UC Approval	Yes – E Course (LOTE)
Fees	None

COURSE DESCRIPTION

ASL II increases vocabulary and fluency, adding facial expressions and body movements. Students learn more about Deaf culture, including taking a look at Deaf artwork and Deaf artists. Students begin to put together complete conversations and spontaneous dialogues with each other and the teacher. Students are also being exposed to situations in which they can use American Sign Language.

AMERICAN SIGN LANGUAGE III

Course Number	0493
Grade Level	9, 10, 11, 12
Pre-Requisite	Grade of C or higher in ASL II.
Application and/or Audition Date	None
Grade Scale	Standard
Credits	10
VCHS Graduation Credit	World Language
UC Approval	Yes – E Course (LOTE)
Fees	None

COURSE DESCRIPTION

ASL III includes over 200 new ASL signs. Dialogues include motivation for learning ASL, professions, commerce, and religious signing. Students learn more ways to use ASL sentence structures in conversation. Facial expression and movement are emphasized.

Additional Expectations: Students have the opportunity to perform a Deaf play and create a Deaf newscast.

AMERICAN SIGN LANGUAGE IV

Course Number	0489
Grade Level	9, 10, 11, 12
Pre-Requisite	Grade of C or higher in ASL III or instructor approval. Summer work review is required with immediate assessment upon arrival back to school.
Application and/or Audition Date	None
Grade Scale	Standard
Credits	10
VCHS Graduation Credit	World Language
UC Approval	Yes – E Course (LOTE)
Fees	None

COURSE DESCRIPTION

This course reviews the fundamentals of sign production. Students master facial expressions and body movements as well as polish the clarity of their signs. Students begin to naturalize the flow in spontaneous conversation. Some Deaf community involvement relevant to today's culture including technology, health, and developing the ability to articulate their spiritual journey in ASL is required. In ASL IV students learn over 500 new ASL vocabulary words.

MANDARIN CHINESE

Mandarin Chinese is the official language of China. It is the most extensively spoken language in the world. More than 874 million people use Mandarin as their first language. Mandarin speakers are in high demand both in public and private sectors. Speaking Mandarin is invaluable in the fields of politics, economics, journalism, healthcare, social services, ministry, and more. It is particularly useful in our own Bay Area with its diverse population.

CHINESE (MANDARIN) I

Course Number	0458
Grade Level	9, 10, 11, 12
Pre-Requisite	Grade of C or higher in English.
Application and/or Audition Date	None
Grade Scale	Standard
Credits	10
VCHS Graduation Credit	World Language
UC Approval	Yes – E Course (LOTE)
Fees	None

COURSE DESCRIPTION

Introduces students to the language and culture of China. This course develops basic reading, speaking, listening and writing abilities in Mandarin Chinese. Students gain an understanding of the customs and culture of historical and modern China. They develop accurate pronunciation through the Pinyin system and through dialogues in which they discuss daily activities using a broad vocabulary base. Chinese I offers a solid foundation of Chinese characters. Students read selections with and without the use of Pinyin and write simplified Chinese characters in simple sentences. The five National Foreign Language Standards are incorporated throughout this course.

CHINESE (MANDARIN) II

Course Number	0416
Grade Level	9, 10, 11, 12
Pre-Requisite	Grade of C or higher in Chinese I.
Application and/or Audition Date	None
Grade Scale	Standard
Credits	10
VCHS Graduation Credit	World Language
UC Approval	Yes – E Course (LOTE)
Fees	None

COURSE DESCRIPTION

This course advances the work of the first year in all skills. Instruction is conducted in Mandarin approximately half of the time. The primary goal continues to be oral proficiency. More advanced reading and writing activities are integrated into the program, as well as further exploration of the culture and history of China. To ensure a smooth transition, some Pinyin is removed in Chinese II so that students read the Mandarin words directly. Topics for second-year learning include colors and clothing, weather and holidays, hobbies, a student's daily routine, school subjects, and making telephone calls. The students learn to express themselves using more sophisticated language structures.

CHINESE (MANDARIN) III

Course Number	0418
Grade Level	9, 10, 11, 12
Pre-Requisite	Grade of C or higher in Chinese II.
Application and/or Audition Date	None
Grade Scale	Standard
Credits	10
VCHS Graduation Credit	World Language
UC Approval	Yes – E Course (LOTE)
Fees	None

COURSE DESCRIPTION

This course builds on all skills developed in Chinese II. Advanced listening comprehension exercises are more challenging. Reading comprehension exercises are presented in different forms such as advertisements, postcards, diary entries, name cards, letters, etc. Students at this level are exposed to authentic written forms. Regular and extended reading challenges students to further explore meanings of new words and phrases. In Mandarin III more emphasis is placed on students speaking with authentic pronunciation and tones. Topics for third-year learning cover terminology for the human body, hospital visits, dining in restaurants, food and health, shopping and living environments, and cultural traditions.

CHINESE (MANDARIN) IV HONORS

Course Number	0421
Grade Level	10, 11, 12
Pre-Requisite	Grade of B or higher in Chinese III.
Application and/or Audition Date	None
Grade Scale	Honors
Credits	10
VCHS Graduation Credit	World Language
UC Approval	Yes – E Course (LOTE)
Fees	None

COURSE DESCRIPTION

This course consists of more advanced work than that of the third year in all skills. It includes approximately 350 new characters. The listening and speaking exercises are carefully designed to reflect the real Chinese-speaking world. Readings at various advanced levels are provided in the workbook in order to reinforce the learning of vocabulary, grammar, and sentence structure. Writing skills are also substantially reinforced.

A writing exercise usually follows each reading comprehension so that the reading material can serve as a model for students to develop their writings. Students read and discuss novels, plays, poetry, newspaper articles, and TV programs. They listen to audio materials such as radio programs, write compositions, give oral reports, and do I-Search projects on topics related to the Chinese culture and language that interest them.

AP CHINESE (MANDARIN) LANGUAGE AND CULTURE

Course Number	0495
Grade Level	9, 10, 11, 12
Pre-Requisite	Grade of B or higher in Chinese IV or instructor recommendation.
Application and/or Audition Date	None
Grade Scale	Honors
Credits	10
VCHS Graduation Credit	World Language
UC Approval	Yes – E Course (LOTE)
Fees	None

COURSE DESCRIPTION

AP Chinese Language and Culture is comparable to a fourth semester college course, deepening students' immersion into the language and culture of the Chinese-speaking world. This course engages students in an exploration of contemporary and historical Chinese culture in the target language, including contemporary Chinese society, geography and population, ethnic and regional diversity, travel and transportation, climate and weather, holidays and food, sports and games, and current affairs. This course introduces students to significant people, products, and themes in Chinese history as well as Chinese contributions to philosophical thought, government institutions, and artistic pursuits like calligraphy, painting, literature, music, folk arts, and culture. Students develop an appreciation of China's global importance in the areas of energy, the environment, economics, and politics. Students hone their language skills across communicative modes: pronunciation, vocabulary, idiomatic expressions, grammatical structures, and written characters. This course incorporates all of the National Standards for Foreign Language Instruction.

FRENCH

The study of French offers great international advantages. Spoken officially in thirty-three countries, French is second only to English and is taught in nearly every country in the world. French is the official language of France and its twelve overseas territories, as well as fourteen other countries. French is considered an international language not only because it is spoken in dozens of countries, but also because it is one of the official working languages in many international organizations.

FRENCH I

Course Number	0400
Grade Level	9, 10, 11, 12
Pre-Requisite	Grade of C or higher in English.
Application and/or Audition Date	None
Grade Scale	Standard
Credits	10
VCHS Graduation Credit	World Language
UC Approval	Yes – E Course (LOTE)
Fees	None

COURSE DESCRIPTION

French I builds an elementary vocabulary of French words and idioms and helps students master correct pronunciation, important grammatical functions, and the present and most common past tenses. There is an emphasis on learning to function in the French language in real life situations. Students learn about the geography and culture of French-speaking countries around the world, and sing French songs. Students memorize and analyze Bible passages in French.

FRENCH II

Course Number	0405
Grade Level	9, 10, 11, 12
Pre-Requisite	Grade of C or higher in French I.
Application and/or Audition Date	None
Grade Scale	Standard
Credits	10
VCHS Graduation Credit	World Language
UC Approval	Yes – E Course (LOTE)
Fees	None

COURSE DESCRIPTION

French II advances vocabulary and grammar study, enabling students to communicate in French with a higher level of proficiency. This course is a continuation of the work done in French I, with an emphasis on writing and speaking French fluently. New verb tenses, grammar, and vocabulary make students more confident in conversation and with the written word. Students memorize and analyze Bible passages in French. Singing and acting out stories make this a fun course.

FRENCH III

Course Number	0410
Grade Level	9, 10, 11, 12
Pre-Requisite	Grade of C or higher in French II.
Application and/or Audition Date	None
Grade Scale	Standard
Credits	10
VCHS Graduation Credit	World Language
UC Approval	Yes – E Course (LOTE)
Fees	None

COURSE DESCRIPTION

French III reviews and advances grammar skills and increases fluency and facility in reading and writing. Students become adept at asking questions and expressing their opinions in real life situations in the French language. Students continue to learn about French culture across the globe. Students memorize and analyze Bible passages in French. Students continue to sing in French. At the end of the year, students read a historical fiction novelette.

FRENCH IV HONORS

Course Number	0415
Grade Level	9, 10, 11, 12
Pre-Requisite	Grade of C or higher in French III.
Application and/or Audition Date	None
Grade Scale	Honors
Credits	10
VCHS Graduation Credit	World Language
UC Approval	Yes – E Course (LOTE)
Fees	None

COURSE DESCRIPTION

French IV Honors expands vocabulary, conversation, and grammar skills. Students delve more deeply into French culture and have regular conversations in French with their peers and instructor. The goal is total immersion in the language. Students memorize and analyze Bible passages in French. Each semester, students read and analyze a complete French work. First semester, students read a full-length French work and write and action/adventure story. Second semester, students read and write an analytical essay about *Le Petit Prince* by St. Exupéry.

LATIN

The benefits of studying Latin are all-encompassing. Closely connected to English, Latin enables students familiar with it to better understand English vocabulary words. Latin students also typically see an increase in SAT scores. Studying Latin vocabulary brings students in contact with word roots, prefixes, and suffixes, which constitute 60% of all English words and 90% of those over two syllables long. Students can also relate more easily to many terms they are asked to learn in geography, biology, astronomy, math, civics, and social studies.

LATIN I

Course Number	0480
Grade Level	9, 10, 11, 12
Pre-Requisite	Grade of C or higher in English.
Application and/or Audition Date	None
Grade Scale	Standard
Credits	10
VCHS Graduation Credit	World Language
UC Approval	Yes – E Course (LOTE)
Fees	None

COURSE DESCRIPTION

Students study both this classical language and the Roman influence on world language, history, and religion. Students master verb declensions, basic vocabulary, and classroom commands. They also translate basic texts. Courses compare and contrast Latin with modern English and study prefixes, suffixes, and the roots of Latin in science, medicine, etc. Students study Roman culture, contrasting and comparing with Christianity.

LATIN II

Course Number	0481
Grade Level	9, 10, 11, 12
Pre-Requisite	Grade of C or higher in Latin I.
Application and/or Audition Date	None
Grade Scale	Standard
Credits	10
VCHS Graduation Credit	World Language
UC Approval	Yes – E Course (LOTE)
Fees	None

COURSE DESCRIPTION

Latin II takes the student deeper into the complexities of Latin by expanding vocabulary to over 1,000 words and by introducing the fifth declension, reflexive pronouns, and the subjunctive mood. Students expand their grasp of Latin history and culture by following the continuing story of a Roman Centurion and his family. Students translate passages of Scripture as well as common sayings such as *e pluribus unum*. Media resources increase comprehension and conversation.

LATIN III

Course Number	0482
Grade Level	9, 10, 11, 12
Pre-Requisite	Grade of C or higher in Latin II.
Application and/or Audition Date	None
Grade Scale	Standard
Credits	10
VCHS Graduation Credit	World Language
UC Approval	Yes – E Course (LOTE)
Fees	None

COURSE DESCRIPTION

Latin III builds on basic Latin language principles by adding creative writing, reports, advanced reading, comprehension, and conversation in the target language. The course includes continuing lessons on English derivatives for Latin words. Advanced grammar is included, along with deeper exploration of culture and history.

LATIN IV HONORS

Course Number	0479
Grade Level	9, 10, 11, 12
Pre-Requisite	Grade of A or higher in Latin III.
Application and/or Audition Date	None
Grade Scale	Honors
Credits	10
VCHS Graduation Credit	World Language
UC Approval	Yes – E Course (LOTE)
Fees	None

COURSE DESCRIPTION

Latin IV Honors advances students' exposure to the classical writers and less common grammatical constructions and idiomatic usages. The course continues to observe English derivatives for new Latin words. Assigned reading and reports increase students' understanding of the culture of the time period as well. Students enjoy Latin history and language.

AP LATIN

Course Number	0484
Grade Level	9, 10, 11, 12
Pre-Requisite	Grade of B or higher in Latin III..
Application and/or Audition Date	None
Grade Scale	Honors
Credits	10
VCHS Graduation Credit	World Language
UC Approval	Yes – E Course (LOTE)
Fees	None

COURSE DESCRIPTION

The AP Latin course is designed to prepare students for success on the AP exam. Students perfect their ability to read, translate, analyze, and interpret segments of the *Aeneid* and Caesar's writing. They reference the mode of expression, metrical qualities, and figures of speech used by Virgil. Students analyze the social, cultural, political, and historical contexts of the *Aeneid* and compare them with current civilizations. AP Latin students recognize the influence of Latin literature on the artistic achievements of the modern world and compare the heroes of the *Aeneid* with contemporary heroes. Students demonstrate a firm knowledge of vocabulary, inflection, and syntax and relate this knowledge to English. AP Latin is the culmination of the study of this classic language.

SPANISH

Spanish is the third most spoken language worldwide. An official language of over twenty-one countries on four continents, Spanish is also one of the official languages of the United Nations, the European Union, and many other organizations. Spanish is spoken natively by nearly twenty-five million people in the U.S., making it the fifth largest Spanish-speaking country in the world. Within a few decades, Spanish is expected to be the first language of over 50% of the U.S. population. An ability to speak Spanish gives students an advantage in employment opportunities and salary potential in a wide range of fields such as law, education, medicine, and the media

SPANISH I

Course Number	0440
Grade Level	9, 10, 11, 12
Pre-Requisite	Grade of C or higher in English.
Application and/or Audition Date	None
Grade Scale	Standard
Credits	10
VCHS Graduation Credit	World Language
UC Approval	Yes – E Course (LOTE)
Fees	None

COURSE DESCRIPTION

Spanish I builds foundational knowledge of the language through listening, speaking, reading, and writing. Students learn the Spanish vocabulary and grammar necessary to function in another country, leaving the course with the ability to hold a simple conversation, write letters, make travel arrangements, and order food.

SPANISH II

Course Number	0445
Grade Level	9, 10, 11, 12
Pre-Requisite	Grade of C or higher in Spanish I.
Application and/or Audition Date	None
Grade Scale	Standard
Credits	10
VCHS Graduation Credit	World Language
UC Approval	Yes – E Course (LOTE)
Fees	None

COURSE DESCRIPTION

Spanish II advances communication, vocabulary, and grammar skills. Students submit creative writing, produce multimedia presentations, and discuss art, music, literature, customs, and current events in Spanish.

SPANISH III

Course Number	0450
Grade Level	9, 10, 11, 12
Pre-Requisite	Grade of C or higher in Spanish II.
Application and/or Audition Date	None
Grade Scale	Standard
Credits	10
VCHS Graduation Credit	World Language
UC Approval	Yes – E Course (LOTE)
Fees	None

COURSE DESCRIPTION

Spanish III reviews in detail the basic structures of the Spanish language, increasing fluency and facility in reading, writing, and speaking.

SPANISH III HONORS

Course Number	0457
Grade Level	9, 10, 11, 12
Pre-Requisite	Grade of B or higher in Spanish II.
Application and/or Audition Date	None
Grade Scale	Honors
Credits	10
VCHS Graduation Credit	World Language
UC Approval	Yes – E Course (LOTE)
Fees	Dual Credit Fees

COURSE DESCRIPTION

Spanish III Honors is intended to prepare students for success in Spanish IV and AP Spanish. They increase their reading and writing skills while continuing to improve their speaking and listening skills. Knowledge of Spanish grammar is honed, and vocabulary acquisition is advanced. Students engage in literary analysis in Spanish. They also learn to exchange information in Spanish with accuracy and within an authentic cultural context. Assignments and assessments are more challenging than those encountered in the regular Spanish III course.

SPANISH IV

Course Number	0455
Grade Level	9, 10, 11, 12
Pre-Requisite	Grade of C or higher in Spanish III.
Application and/or Audition Date	None
Grade Scale	Standard
Credits	10
VCHS Graduation Credit	World Language
UC Approval	Yes – E Course (LOTE)
Fees	None

COURSE DESCRIPTION

Spanish IV develops proficiency in the Spanish language through advanced grammar, extensive vocabulary, and deeper-level conversation. Projects include creating videos, and students read novels, the Bible, and Spanish-language publications.

AP SPANISH LANGUAGE & CULTURE

Course Number	0456
Grade Level	9, 10, 11, 12
Pre-Requisite	Grade of A in Spanish III; B or higher in Spanish IV. It is strongly encouraged that students complete Spanish IV before enrolling in AP Spanish.
Application and/or Audition Date	None
Grade Scale	Honors
Credits	10
VCHS Graduation Credit	World Language
UC Approval	Yes – E Course (LOTE)
Fees	None

COURSE DESCRIPTION

AP Spanish Language and Culture prepares students to excel on the AP Spanish Language examination through the integration of reading, writing, speaking, and listening using authentic sources in Spanish. Through the use of these multi-media sources, students become familiar with the various regional accents of Spanish speakers. Resources include radio and online sources from various countries, literature from several Hispanic countries and current events, and issues relevant to Hispanic life. Students master the highest level of Spanish grammar and practice their skills in writing and conversation.



ELECTIVES



ELECTIVE COURSES OFFERED

- Scientific Research
- ASB Student Government
- Study Hall
- Teacher's Aide
- Specialized Aide
- Open Period or Unscheduled
- Language Skills for International Students

SCIENTIFIC RESEARCH

Course Number	0650
Grade Level	11, 12
Pre-Requisite	<i>Students must have a 3.0 unweighted GPA, completed biology, enrolled or completed chemistry. An application must be approved by the instructors.</i>
Application and/or Audition Date	Spring 2017
Grade Scale	Standard
Credit	10
VCHS Graduation Credit	Elective
UC Approval	None
Fees	<i>\$250 to cover lab notebooks and laboratory coats, personal protection equipment.</i>

COURSE DESCRIPTION

Scientific Research Course is designed for students with an interest in careers in the biological sciences involving research. Through the process of developing, designing and conducting a science research project students learn valuable research skills. These skills include but are not limited to the reading of primary literature, problem solving, critical thinking and focused curiosity. Students practice science communication skills and are expected to communicate their research and results at the Synopsys Science and Technology Championship presented by the Santa Clara Valley Science and Engineering Fair Association. The BSL-1 laboratory course is designed for mammalian cell or model organism research questions. Discussion topics include analysis of claims, false claims, career opportunities, peer-review, model organisms, cell culture, biotechnology, and basic lab skills and research equipment. Interested will need to fill out an application and meet with the instructor to discuss proposed research prior to acceptance into the class.

Additional Expectations: Students keep a laboratory notebook with regular entries, meet the deadlines for written checkpoints, topic talks, and research proposals. The course models a research community including participating in peer review of student projects. Self-motivation and a desire to complete research is a key component to student success in this course.

ASB STUDENT GOVERNMENT

Course Number	0910
Grade Level	11, 12
Pre-Requisite	<i>Application and instructor approval; concurrent enrollment in ASB Biblical Government</i>
Application and/or Audition Date	February 10
Grade Scale	Standard
Credits	10
VCHS Graduation Credit	Elective
UC Approval	No
Fees	None

COURSE DESCRIPTION

Designed for elected ASB President appointed Vice Presidents and appointed representatives, this course emphasizes the practical aspects of leadership, budget planning and implementation, and the coordination of activities for the student body while developing and emphasizing school culture.

Additional Expectations: Students are required to attend all ASB functions, including school dances and evening rallies. Students have frequent lunch time responsibilities, including ticket sales and organizing lunch time activities. Many evening events require additional time (setup the night before, arriving early and staying late for setup and cleanup, etc.).

STUDY HALL

Course Number	0975
Grade Level	9, 10, 11, 12
Pre-Requisite	Parental permission; Counselor approval.
Application and/or Audition Date	None
Grade Scale	Pass/Fail
Credits	0
VCHS Graduation Credit	None
UC Approval	None
Fees	None

COURSE DESCRIPTION

This is a supervised time during which students may work on school assignments. Students are expected to be on task, and the supervising teacher checks student grades twice a month to monitor each student's progress.

This course may be chosen as an elective, but no credit is earned toward graduation.

Limit: One Study Hall per year.

TEACHER'S AIDE

Course Number	0955
Grade Level	11, 12
Pre-Requisite	GPA of 2.5 or above; Good citizenship; Instructor approval.
Application and/or Audition Date	None
Grade Scale	Pass/Fail
Credits	2.5/2.5
VCHS Graduation Credit	Elective
UC Approval	None
Fees	None

COURSE DESCRIPTION

The TA program offers juniors and seniors an opportunity to learn and enhance organizational and administrative skills in a classroom setting. Students provide teachers with needed support and practical assistance in various teaching areas. Typical duties for the TA include filing, bulletin board maintenance, classroom set-up and organization, and teacher-supervised assistance.

SPECIALIZED AIDE

Course Number	0988
Grade Level	11, 12
Pre-Requisite	GPA of 2.5 or above; Good citizenship; Instructor approval.
Application and/or Audition Date	None
Grade Scale	Standard
Credits	5/5
VCHS Graduation Credit	Elective
UC Approval	None
Fees	None

COURSE DESCRIPTION

Students may seek a position as a specialized aide, assisting in the office, library, or advanced course. The specialized aide program offers juniors and seniors the opportunity to apply existing skills to an authentic classroom or office environment. Students who want to participate must have previous experience that demonstrates high levels of responsibility and knowledge in the specialized area. Students need to possess self-starter qualities and an ability to observe which actions are needed and then fulfill them. Strict adherence to the guidelines set forth by the supervisor are mandatory to remain in these internship-level positions.

OPEN PERIOD OR UNSCHEDULED

Course Number	0998
Grade Level	12
Pre-Requisite	None
Application and/or Audition Date	None
Grade Scale	NA
Credits	0
VCHS Graduation Credit	None
UC Approval	None
Fees	None

COURSE DESCRIPTION

An unscheduled morning or afternoon period is available only to seniors who opt to take a reduced academic load of six courses. VCHS does not recommend that seniors take an unscheduled period.

LANGUAGE SKILLS FOR INTERNATIONAL STUDENTS

Course Number	1001
Grade Level	9, 10, 11, 12
Pre-Requisite	<i>Must be an international student.</i>
Application and/or Audition Date	None
Grade Scale	Standard
Credits	2.5/2.5
VCHS Graduation Credit	Elective
UC Approval	None
Fees	None

COURSE DESCRIPTION

Language Skills for International Students focuses on three areas: an introduction to the Bible illustrating how Jesus is the hero of the Bible, academic vocabulary, and writing and revision assignments. International students have an opportunity to practice and hone their skills, as well as receive additional support in their Bible, English and social science courses.



Valley Christian Schools' mission is to provide a nurturing environment offering quality education supported by a strong foundation of Christian values in partnership with parents, equipping students to become leaders to serve God, to serve their families, and to positively impact their communities and the world.



VALLEY CHRISTIAN
WARRIORS